

*A Project report  
on*

**MINE SAFE: IOT BASED SMART HELMET FOR MINING  
WORKERS**

*Submitted in partial fulfillment of the requirements  
for the award of the degree of*

**BACHELOR OF TECHNOLOGY**

*in*

**COMPUTER SCIENCE & ENGINEERING**

*By*

<b>J. R. YASHASWINI</b>	<b>(204G1A05C5)</b>
<b>P. PAVAN</b>	<b>(204G1A0571)</b>
<b>M. TUFEL BASHA</b>	<b>(204G1A05B3)</b>
<b>P. DIVYA</b>	<b>(194G1A0528)</b>

Under the Guidance of

**Mr. P. Praneel Kumar** M.Tech., (Ph.D),



**Department of Computer Science & Engineering**

**SRINIVASA RAMANUJAN INSTITUTE OF TECHNOLOGY  
(AUTONOMOUS)**

**Rotarypuram Village, B K Samudram Mandal, Ananthapuramu - 515701**

**2023-2024**

# SRINIVASA RAMANUJAN INSTITUTE OF TECHNOLOGY

(AUTONOMOUS)

(Affiliated to JNTUA, Accredited by NAAC with 'A' Grade, Approved by AICTE, New Delhi & Accredited by NBA (EEE, ECE & CSE)

Rotarypuram Village, BK Samudram Mandal, Ananthapuramu-515701

## DEPARTMENT OF COMPUTER SCIENCE & ENGINEERING



### Certificate

This is to certify that the project report entitled **MINE SAFE: IOT BASED SMART HELMET FOR MINIG WORKERS** is the bonafide work carried out by **J. R. Yashaswini, P. Pavan, M. Tufel Basha, P. Divya** bearing Roll Number **204G1A05C5, 204G1A0571, 204G1A05B3, 194G1A0528** in partial fulfilment of the requirements for the award of the degree of **Bachelor of Technology** in **Computer Science & Engineering** during the academic year 2023-2024.

  
Project Guide

Mr. P. Praneel Kumar M.Tech., (Ph.D),

Assistant Professor

  
Head of the Department

Dept. of Computer Science & Engineering

Srinivasa Ramanujan Institute of Technology (Autonomous)

Assistant Professor & HOD

Date: 20/4/2024

Place: Rotarypuram

External Examiner



## DECLARATION

We, Ms. J. R. Yashaswini with reg no: 204G1A05C5, Mr. P. Pavan with reg no: 204G1A0571, Mr. M. Tufel Basha with reg no: 204G1A05B3, Ms. P. Divya with reg no: 194G1A0528 students of SRINIVASA RAMANUJAN INSTITUTE OF TECHNOLOGY, Rotarypuram, hereby declare that the dissertation entitled “**MINE SAFE: IOT BASED SMART HELMET FOR MINING WORKERS**” embodies the report of our project work carried out by us during IV year Bachelor of Technology under the guidance of **Mr. P. Praneel Kumar** M.Tech., (Ph.D), Department of CSE, **SRINIVASA RAMANUJAN INSTITUTE OF TECHNOLOGY**, and this work has been submitted for the partial fulfillment of the requirements for the award of the Bachelor of Technology degree.

The results embodied in this project have not been submitted to any other University of Institute for the award of any Degree or Diploma.

J. R. YASHASWINI

Reg. No. 204G1A05C5

P. PAVAN

Reg. No. 204G1A0571

M. TUFEL BASHA

Reg. No. 204G1A05B3

P. DIVYA

Reg. No. 194G1A0528

## **Vision & Mission of the SRIT**

### **Vision:**

To become a premier Educational Institution in India offering the best teaching and learning environment for our students that will enable them to become complete individuals with professional competency, human touch, ethical values, service motto, and a strong sense of responsibility towards environment and society at large.

### **Mission:**

- Continually enhance the quality of physical infrastructure and human resources to evolve in to a center of excellence in engineering education.
- Provide comprehensive learning experiences that are conducive for the students to acquire professional competences, ethical values, life-long learning abilities and understanding of the technology, environment and society.
- Strengthen industry institute interactions to enable the students work on realistic problems and acquire the ability to face the ever-changing requirements of the industry.
- Continually enhance the quality of the relationship between students and faculty which is a key to the development of an exciting and rewarding learning environment in the college.

## **Vision & Mission of the Department of CSE**

### **Vision:**

To evolve as a leading department by offering best comprehensive teaching and learning practices for students to be self-competent technocrats with professional ethics and social responsibilities.

### **Mission:**

**DM 1:** Continuous enhancement of the teaching-learning practices to gain profound knowledge in theoretical & practical aspects of computer science applications.

**DM 2:** Administer training on emerging technologies and motivate the students to inculcate self-learning abilities, ethical values and social consciousness to become competent professionals.

**DM 3:** Perpetual elevation of Industry-Institute interactions to facilitate the students to work on real-time problems to serve the needs of the society.

# ACKNOWLEDGEMENT

The satisfaction and euphoria that accompany the successful completion of any task would be incomplete without the mention of people who made it possible, whose constant guidance and encouragement crowned our efforts with success. It is a pleasant aspect that we have now the opportunity to express our gratitude for all of them.

It is with immense pleasure that we would like to express our indebted gratitude to our Guide **Mr. P. Praneel Kumar**, M.Tech., (Ph.D), **Assistant Professor, Computer Science & Engineering**, who has guided us a lot and encouraged us in every step of the project work. We thank him for the stimulating guidance, constant encouragement and constructive criticism which have made possible to bring out this project work.

We express our deep-felt gratitude to **Mr. C. Lakshminatha Reddy, Assistant Professor** and **Mr. M. Narasimhulu, Assistant Professor**, Project Coordinators for their valuable guidance and unstinting encouragement enabled us to accomplish our project successfully in time.

We are very much thankful to **Mr. P. Veera Prakash**, M.Tech., (Ph.D.), **Assistant Professor & Head of the Department, Computer Science & Engineering**, for his kind support and for providing necessary facilities to carry out the work.

We wish to convey our special thanks to **Dr. G. Bala Krishna, Ph.D., Principal of Srinivasa Ramanujan Institute of Technology** for giving the required information in doing our project work. Not to forget, we thank all other faculty and non - teaching staff, and our friends who had directly or indirectly helped and supported us in completing our project in time.

We also express our sincere thanks to the Management for providing excellent facilities.

Finally, we wish to convey our gratitude to our families who fostered all the requirements and facilities that we need.

## Project Associates

204G1A05C5	J. R. YASHASWINI
204G1A0571	P. PAVAN
204G1A05B3	M. TUFEL BASHA
194G1A0528	P. DIVYA

# ABSTRACT

Mining is recognized as one of the most hazardous occupations globally. The death rate of mining workers at mining sites is increasing day by day. Considering this, we cannot simply avoid mining because it plays a vital role. Instead, an alternative solution is to implement safety measures and continue operations in mines.

To ensure the well-being of workers and protect them from potential health hazards, we propose a smart and adaptable helmet for workers. This advanced helmet incorporates a range of specialized sensors to monitor both environmental conditions and workers health. Environmental monitoring is facilitated by Gas sensor, Temperature and Humidity sensor, ensuring that workers are protected from hazardous conditions. Simultaneously, the helmet employs Accelerometer and Gyroscope sensors, IR sensor, Heart Rate sensor to monitor worker's conditions. Furthermore, an integrated emergency button enables miners to request help swiftly, triggering alerts that pinpoint their exact location. Instead of relying on traditional loud alarms, the helmet communicates crucial information to the miner through a voice interface, offering real-time updates and guidance during emergency situations. The developed helmet system is primarily intended to improve the working environment in mines and ensure worker safety.

## **Keywords**

Smart Helmet, Accelerometer and Gyroscope sensor, Voice interface module.

# CONTENTS

	<b>Page No.</b>
<b>List of Figures</b>	<b>X - XI</b>
<b>List of Tables</b>	<b>XII</b>
<b>List of Abbreviations</b>	<b>XIII</b>
<b>Chapter 1</b>	
<b>Introduction</b>	<b>1-3</b>
1.1 Problem Statement	2
1.2 Objectives	2
1.3 Scope	3
<b>Chapter 2</b>	
<b>Literature Survey</b>	<b>4-5</b>
<b>Chapter 3</b>	
<b>Planning</b>	<b>6-29</b>
3.1 Existing System	6
3.1.1 Disadvantages	7
3.2 Proposed System	8
3.2.1 Advantages	8
3.3 Hardware Requirements	9
3.3.1 Arduino Mega 2560	9
3.3.2 DHT 11 Sensor	10
3.3.3 MQ-2 Gas Sensor	11
3.3.4 Infrared Sensor	12
3.3.5 Heart rate Sensor	12
3.3.6 MEMS Sensor	13-14
3.3.7 LCD Display	15
3.3.8 ESP8266 Wi-Fi Module	15
3.3.8.1 Serial Communication	16

	3.3.9 GSM Module	17
	3.3.10 GPS Module	18
	3.3.11 APR33A3 Voice Playback Module	19-20
	3.3.12 Speakers	21
	3.3.13 Battery	21
	3.4 Software Requirements	22
	3.4.1 Arduino IDE	22
	3.4.2 Programming Language	23
	3.4.3 ThingSpeak	24
	3.5 Functional Requirements	25
	3.6 Non-Functional Requirements	25
	3.6.1 Usability	25
	3.6.2 Portability	25
	3.6.3 Speed	25
	3.6.4 Real-Time Responsiveness	26
	3.7 Performance	26
	3.8 Methodology	26
	3.8.1 Advantages	27
	3.9 Cost Estimation	28
	3.10 Time Estimation	28-29
<b>Chapter 4</b>	<b>Design</b>	<b>30-32</b>
	4.1 System Architecture	30
	4.2 Flow Chart	31-32
<b>Chapter 5</b>	<b>Implementation</b>	<b>33-51</b>
	5.1 Software Implementation	33
	5.1.1 Installation of Arduino Uno IDE	33-38

	5.1.2 Source Code	38-51
<b>Chapter 6</b>	<b>Testing</b>	<b>52-54</b>
	6.1 Testing Approach	52
	6.2 Features to be tested	52
	6.3 Testing Tools and Environment	53
	6.4 Test Cases	53
	6.4.1 Inputs	53
	6.4.2 Expected Output	53
	6.4.3 Testing Procedure	53-54
<b>Chapter 7</b>	<b>Result</b>	<b>55-58</b>
<b>Chapter 8</b>	<b>Conclusion</b>	<b>59</b>
	<b>References</b>	<b>60</b>
	<b>Paper Publications</b>	
	<b>Certificates</b>	

## List of Figures

<b>Fig No.</b>	<b>Description</b>	<b>Page No.</b>
3.1	Arduino Uno	10
3.2	DHT 11 Sensor	11
3.3	MQ-2 Gas Sensor	11
3.4	IR Sensor	12
3.5	Heart Rate Sensor	12
3.6	Block Diagram of lclm358	13
3.7	MEMS Sensor	14
3.8	LCD Display	15
3.9	ESP8266 Wi-Fi Module	15
3.10	Serial Communication	16
3.11	GSM Module	17
3.12	GPS Module	18
3.13	APR33A3 Voice Playback Module	19
3.14	Speaker	21
3.15	Arduino Uno IDE	23
3.16	ThingSpeak Cloud	24
3.17	Iterative Model	27
4.1	Block Diagram	30
4.2	Flow Chart	31
5.1	Download Arduino Uno IDE on Windows	33
5.2	Arduino Setup-Installation Options	34
5.3	Arduino Setup Installation Folder	34
5.4	Arduino Setup-Installing	35
5.5	USB cable and Arduina Mega board	35
5.6	Represents how to connect USB cable with Mega board	36
5.7	Path to Select Board	37
5.8	Path to Add Zip Library	37
5.9	Selecting a Zip File	38
5.10	Path to Select Serial Port	38

5.11	Path to Upload and Compile	51
7.1	Smart Helmet	55
7.2	ThinkSpeak Sensor Data Analysis through data provided by temperature, Humidity, gas and pulse sensor	56
7.3	ThinkSpeak sensor data Analysis through data provided by IR, MEMS Sensor	56
7.4	Alert due to Hazardous gas detection	57
7.5	Alert due to Fall detection	57

## **List of Tables**

<b>Table No.</b>	<b>Table Name</b>	<b>Page No.</b>
3.1	Cost Estimation	27
3.2	Time Estimation	28

## List of Abbreviations

IOT	Internet Of Things
IR	Infrared
DHT	Digital Temperature and Humidity Sensor
GPS	Global Positioning System
GSM	Global System for Mobile Communications
SMS	short message service
MEMS	micro-electromechanical system
LCD	Liquid-crystal display
USB	Universal Serial Bus
AC	Alternating Current
AFH	Adaptive Frequency Hopping
DC	Direct Current
DSP	Digital Signal Processor
DVR	Distance Vector Routing
HIC	Head Injury Criteria
IDE	Integrated Development Environment
LED	Light Emitting Diode
OHS	Occupational Health and Safety
PCB	Printed Circuit Board
RNG	Random Number Generator
TVOC	Total Volatile Organic Compounds
USB	Universal Serial Bus
WSN	Wireless Sensor Network

# CHAPTER-1

## INTRODUCTION

In the contemporary landscape of industrial innovation and technological advancement, the integration of smart solutions has become increasingly pivotal across various sectors. One such domain that has witnessed transformative developments is the mining industry, a cornerstone of economic prosperity for nations worldwide. This paper delves into the critical intersection of technology and mining safety, addressing the multifaceted challenges faced by miners and proposing an innovative approach to enhance their well-being and security. The benefits generated by this industry contribute significantly to local communities by processing the materials it offers. However, working in mining poses specific health and safety risks, especially in challenging or unpredictable conditions. As mines expand, the risks associated with completing tasks also increase. The mining industry is complex, involving intricate operations conducted within tunnels, underground passages, and other challenging environments. The intricate nature of mining operations presents a variety of risk variables that may compromise the well-being and security of miners. The Chasnala mining tragedy in the Indian state of Jharkhand, close to Dhanbad, is a heartbreaking example. Almost 372 miners' lives were almost lost in this tragedy, which is regarded as one of the deadliest in the history of the mining industry.

Miners frequently encounter unnoticed environmental factors such as changes in pressure and temperature. The lives of excavators are in grave danger when they crash with big things like hard rocks or mining equipment. The inhalation of dangerous gases poses a substantial risk of injury to miners and is considered a severe threat. Miners are cut off from outside communication under such circumstances.

Recognizing the need for proactive safety measures, this paper explores the development of a smart protective helmet system designed to detect and respond to hazardous events in real-time. Beyond event detection, the system encompasses environmental monitoring, GPS tracking, and the provision of oxygen enhancements to mitigate risks associated with toxic gases. The proposed system not only addresses the immediate safety concerns but also serves as a forward-looking initiative to ensure the well-being of miners

in the evolving landscape of the mining industry.

Moreover, considering the rising prominence of the mining sector in certain regions, such as Pakistan with its substantial coal reserves, the paper discusses the challenges faced in making sure that miners are safe. The convergence of technological solutions, such as microcontroller-based monitoring systems and the Internet of Things (IoT), presents as a pivotal strategy to overcome these challenges and fortify the safety infra- structure within the mining industry.

In navigating this discourse, the aim is to contribute to the ongoing dialogue on mining safety by presenting an integrated and forward-thinking approach. By leveraging cutting- edge technologies and innovative solutions, we strive to redefine the safety paradigm for miners, fostering a safer, more secure environment for those working at the heart of eco-nomic prosperity.

### **1.1 Problem Statement**

- In underground mining there is a concern about the safety of the workers due to its highly changing environment. Thousands of miners die from mining accidents every year.
- To save the workers life and to improve safety in mining environment it is important to take some safety measures and to improve communication between workers and control stations to avoid life threatening situations.
- With the help of the smart helmet, we can provide security and rescue measures in case of any emergency conditions.

### **1.2 Objective**

- To develop an advanced smart helmet system with a diverse set of sensors, including environmental sensors (such as gas, temperature, and humidity), an Accelerometer and Gyroscope sensor for fall detection, IR sensor for helmet usage verification and Heart Rate sensor to measure the heart pulse rate.
- To Implement an intelligent alert system using voice notifications through the APR33A3 voice playback module.

## 1.2 Scope

This project holds broad applicability across diverse mining contexts, encompassing coal, metal, and mineral mining operations globally. Its adaptability extends to both underground and open-pit mining environments, addressing specific safety challenges in each setting. The system's scalability makes it suitable for various scales of mining operations, from small-scale to large industrial endeavors. With a focus on global implementation, the project caters to regional variations in mining practices, safety regulations, and environmental conditions. Overall, the "Mine Safe" system offers a comprehensive safety solution applicable to the varied landscape of mining activities worldwide.

## CHAPTER-2

### LITERATURE SURVEY

[1] Proposed A system which uses a variety of sensors to monitor workplaces. It incorporates the DHT11 sensor for environmental temperature and humidity monitoring and the MQ2 sensor for recognizing dangerous substances. The Smart helmet is equipped with a Wi-Fi module for Internet of Things connectivity, a GPS location tracker, and a GSM modem for delivering emergency SMS messages. This system is particularly used for detecting safety at workplaces but not for the workers.

[2] This paper introduces an Intelligent Helmet system equipped with various sensors and utilizing Zigbee protocol for real-time monitoring of hazardous conditions. The proposed system integrates multiple sensors, including temperature, methane gas, and heart rate, with a Zigbee mesh network ensuring reliable data transmission for timely alerting and emergency response.

[3] This System proposed a wearable IoT-enabled jacket specifically crafted to safeguard individuals employed in coal mines, often subjected to potential hazards. This prototype is engineered to detect multiple factors such as harmful chemicals, the heartbeat of a coal miner, underground conditions, and the miner's GPS location. The collected data is intended to be transmitted accessing an ever-changing internet protocol using an encrypted Wi-Fi channel

[4] Hazardous environments at the workplace are a significant contributor to injuries due to accidents as well as chronic diseases. There are many occupational health and safety (OHS) systems, but they are costly or not flexible. This paper presents a low-cost OHS. It consists of various sensors that can be used to monitor whether a safety helmet is being worn, the worker is mobile and safety boots are being worn. The system interfaces with a wireless sensor network and is suitable for operation in environments such as underground mines and sawmills.

[5] This paper presents implementation of safety helmet for coal mine workers. This helmet is equipped with methane and carbon monoxide gas sensor. This sensor senses the gas and data is transmitted to the control room wirelessly, through a wireless module called X-Bee connected with the helmet. When the methane or carbon-monoxide gas concentration is beyond the critical level, controller in the control room triggers an

alarm and keeps the plant and the workers safe by preventing an upcoming accident.

[6] In order to solve such problems of the mine cable gas monitoring system as high costs, inconvenient maintenance, hindering wiring and unmovable monitoring information points, a mine safety helmet is designed, based on wireless sensors networks, which studies the hardware design, gas concentration calculations and its dynamic compensation algorithm, as well as the experimental design of gas monitoring system in mine safety helmet so as to ensure the correct calculation of the gas concentration. The innovative point of this essay is the combination of the ordinary LED cap lamp and the wireless sensors networks, which ensures a real-time, dynamic collection of the information of the gas concentration around the workers.

[7] Temperature and Pressure sensors are used for the continuous monitoring of environmental conditions. The information are sent to the control room through wireless network. The layout of the visualization was completed and displayed in the control room with the help of a Lab VIEW software. This paper presents the undertaken design detailing solutions to issues raised in previous research.

[8] The critical levels of the hazardous gases such as CO, SO<sub>2</sub> and NO<sub>2</sub> in the mines industry has been indicated through alerting unit. The helmet removal test was done successfully with an off the-shelf IR distance sensor. The IR sensor designed from first principles was working device.

## CHAPTER-3

### PLANNING

#### 3.1 Existing System

In the existing mining system, the conventional helmet functions as a protective measure against potential hazards, ensuring the safety of miners. However, this system has inherent limitations. While the primary purpose of the helmet is to shield the head from injuries, challenges arise in maintaining environmental awareness. The weight and discomfort of the helmet often prompt miners to remove it, subjecting them to unsafe conditions. Additionally, the existing system lacks fall detection capabilities, presenting a potential risk as workers may faint and fall unexpectedly, particularly when exposed to dangerous gases in the mining area. Miners also face the danger of colliding with substantial objects like mining equipment or hard rocks, exposing them to severe life-threatening risks. In such scenarios, a fall detection sensor plays a crucial role, addressing a significant gap in the capabilities of existing helmets.

The current alert system relies on a buzzer, which activates in the event of any abnormal condition. However, it lacks specificity regarding the particular condition, making it challenging to discern the reason for the alert. Having a system that specifies the exact cause during alerts would enhance our understanding and enable us to respond more cautiously to the identified cause.

##### 3.1.1 Disadvantages

- Traditional helmets focus primarily on protecting the head but lack sensors for real-time monitoring of environmental conditions. Miners may be unaware of changes in temperature, humidity, or the presence of hazardous gases, exposing them to potential risks.
- Conventional helmets lack advanced fall detection capabilities, making it challenging to promptly identify and respond to miners who may experience unexpected falls. This limitation poses a significant risk, especially in dynamic and challenging mining environments.
- The alert systems in traditional helmets typically rely on generic buzzers that activate during abnormal conditions. However, these alerts lack specificity,

providing little information about the nature of the emergency. Miners may struggle to understand the exact cause, hindering their ability to respond effectively.

- The existing systems often lack efficient communication channels, especially during emergencies. Miners may face difficulties in quickly and accurately communicating their situation or requesting assistance, leading to potential delays in response times.
- Conventional helmets do not incorporate advanced sensors to detect specific environmental hazards, such as the presence of toxic gases. This limitation can result in delayed responses to dangerous conditions, putting miners at risk of exposure to harmful substances.

### **3.2 Proposed System**

The innovation at hand represents a groundbreaking development in workplace safety – an advanced protective helmet equipped with a sophisticated array of sensors designed for exhaustive detection and analysis. This pioneering system integrates two primary categories of sensors: environmental sensors for monitoring workplace conditions and sensors dedicated to tracking the well-being of workers. Within the suite of environmental sensors, a gas sensor is employed to detect hazardous gases, while temperature and humidity sensors identify abnormal fluctuations in the work environment.

Simultaneously, the system monitors the condition of workers through the integration of specialized sensors, including a pulse sensor for real-time tracking of heart rates, an infrared sensor ensuring continuous helmet usage, and a MEMS sensor designed to detect sudden falls. The continuous monitoring by these sensors ensures a holistic approach to workplace safety.

In the event of abnormal conditions where tracked values surpass predefined thresholds, the system activates a unique sound alert. Diverging from conventional buzzers, the system employs an APR33A3 voice module, providing a detailed sound alert that specifies the exact cause of the triggered response. This precise communication is crucial for enabling swift and informed reactions to potential hazards.

Beyond localized alerts, the system ensures wider communication by sending alert messages to registered mobile numbers, accompanied by GPS location details facilitated by GSM and GPS modules. This integration enhances emergency response capabilities, allowing for timely and accurate intervention in critical situations.

To facilitate comprehensive data management, the system incorporates a WiFi module that stores information on Thing Speak. This not only ensures real-time data access but also enables data retention for future references and predictive analyses. In essence, the advanced helmet system emerges as a cutting-edge solution that goes beyond traditional safety measures. It elevates workplace safety through its capabilities for real-time monitoring, precise alerts, and the generation of data-driven insights, marking a significant leap forward in ensuring the well-being of workers in diverse industrial settings.

### **3.2.1 Advantages**

- The proposed system integrates environmental sensors, including gas, temperature, and humidity sensors, providing comprehensive monitoring of workplace conditions. This ensures early detection of hazardous gases and abnormal fluctuations, enhancing overall safety.
- Specialized sensors such as the pulse sensor enable real-time tracking of workers' heart rates, offering continuous health monitoring. This feature enhances the system's capability to address potential health risks promptly.
- The inclusion of a MEMS sensor enables the detection of sudden falls, a crucial safety feature in environments where workers may face the risk of fainting or unexpected accidents. This significantly reduces the response time to critical situations.
- Unlike traditional alert systems, the proposed system employs an APR33A3 voice module, providing detailed and specific alerts. This enhances communication during emergencies, allowing for a more informed and timely response to identified causes.
- The inclusion of various modes of communication, such as localized sound alerts, SMS messages to registered mobile numbers, and GPS location details facilitated by GSM and GPS modules, ensures a robust and multi-channel communication

network. This diversity in communication modes enhances the reach and effectiveness of alerting mechanisms.

### **3.3 Hardware requirements**

- Arduino Mega 2560
- DHT 11 Sensor
- MQ-2 Gas Sensor
- Infrared Sensor
- Heart Rate Sensor
- MEMS Sensor
- LCD Display
- ESP8266 Wi-Fi Module
- GSM Module
- GPS Module
- APR33A3Voice Playback Module
- Speakers
- Battery

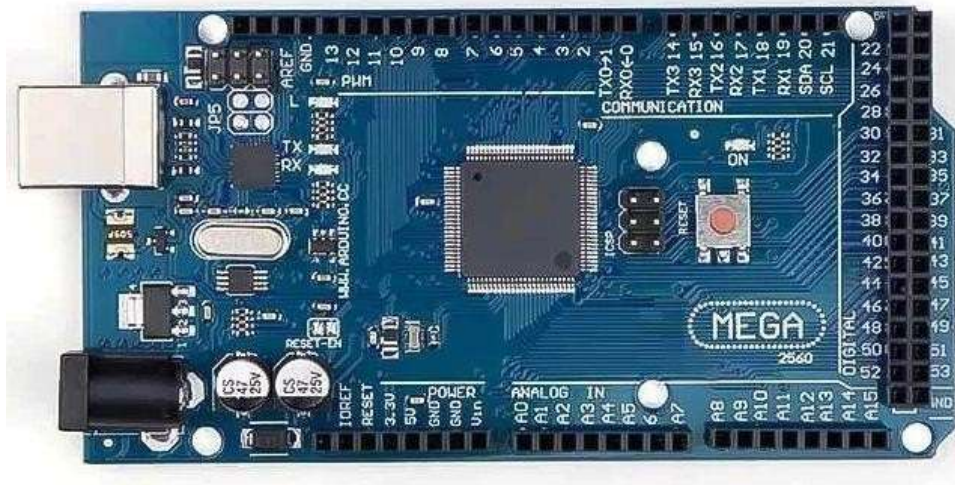
#### **3.3.1 Arduino Mega 2560**

The Arduino Mega 2560 is an open-source microcontroller board based on the ATmega2560 microcontroller, providing a versatile and user-friendly platform for a wide range of applications. With 54 digital input/output pins, including 16 analog inputs and 14 PWM outputs, this board is well-equipped for various projects. It features four hardware serial ports (UARTs), a 16 MHz crystal oscillator, an ICSP header, a power jack, a USB connection, and an RST button.

Powering the Arduino Mega 2560 is straightforward, as it can be connected to a PC via USB, powered by a battery, or connected to an AC-DC adapter. The board's design includes measures to protect it from unexpected electrical discharges, making it suitable for diverse environments. Notably, the board's adaptability extends to working with existing shields and accommodating newer shields utilizing additional pins.

The specifications of the Arduino Mega 2560 include an operating voltage of 5 volts, a recommended input voltage ranging from 7 to 12 volts, and 54 digital I/O pins,

16 analog input pins, and 15 PWM outputs. It features a clock speed of 16 MHz, with flash memory of 256 KB (8 KB used by the bootloader), 8 KB of static random-access memory (SRAM), and 4 KB of electrically erasable programmable read-only memory (EEPROM).



**Fig 3.1:** Arduino Uno

The board's pin configuration is detailed, covering essential pins like 3.3V and 5V for regulated output voltage, GND pins, a reset (RST) pin for board resetting, and VIN pin for input voltage. Serial communication is facilitated through TXD and RXD pins, with four combinations for different serial ports. External interrupts are generated by specific pins, and the board includes LEDs connected to pin 13 for real-time programming feedback.

The Arduino Mega 2560 supports analog reference voltage (AREF), and its analog pins (A0-A15) offer 10-bit resolution, measuring from GND to 5 volts. It supports I2C communication with SDA and SCL pins and SPI communication through MISO, MOSI, SCK, and SS pins. The dimensions of the board are 101.52 mm in length, 53.3 mm in width, and it weighs 36 g.

### 3.3.2 DHT 11 Sensor

It's fairly simple to use but requires careful timing to grab data. The only real downside of this sensor is you can only get new data from it once every 2 seconds, so when using our library, sensor readings can be up to 2 seconds old.



**Fig 3.2:** DHT 11 Sensor

Compared to the DHT22, this sensor is less precise, less accurate, and works in a smaller range of temperature/humidity, but its smaller and less expensive. The DHT11 is a commonly used Temperature and humidity sensor that comes with a dedicated NTC to measure temperature and an 8-bit microcontroller to output the values of temperature and humidity as serial data. The sensor is also factory calibrated and hence easy to interface with other microcontrollers. DHT11 sensor consists of a capacitive humidity sensing element and a thermistor for sensing temperature. The humidity sensing capacitor has two electrodes with a moisture holding substrate as a dielectric between them.

### 3.3.3 MQ-2 Gas Sensor



**Fig 3.3:** MQ2 Gas Sensor

Sensors are the electronic devices used for interaction with the outer environment. There are various types of sensors available that can detect light, noise, smoke, proximity etc. With the advent in technology, these are available as both analog and digital forms. Besides forming a communication with the outer environment, sensors are also a crucial part of safety systems. Fire sensors are used to detect the fire and take appropriate precautions on time. For smooth functioning of control systems and sensitive electronics, humidity sensors are used for maintaining humidity in the unit. One of such sensors used in safety systems to detect harmful gases is MQ2 Gas sensor.

### 3.3.4 Infrared Sensor



**Fig 3.4:** IR Sensor

IR sensor is an electronic device, that emits the light in order to sense some object of the surroundings. An IR sensor can measure the heat of an object as well as detects the motion. Usually, in the infrared spectrum, all the objects radiate some form of thermal radiation. These types of radiations are invisible to our eyes, but infrared sensor can detect these radiations.

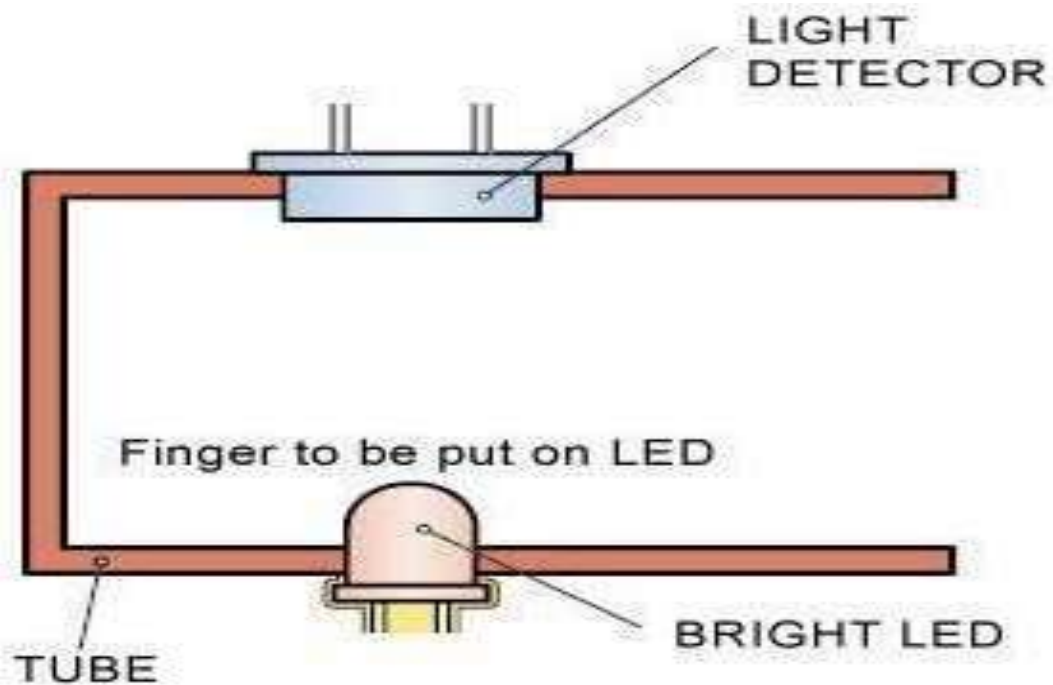
The emitter is simply an IR LED (Light Emitting Diode) and the detector is simply an IR photodiode. Photodiode is sensitive to IR light of the same wavelength which is emitted by the IR LED. When IR light falls on the photodiode, the resistances and the output voltages will change in proportion to the magnitude of the IR light received.

### 3.3.5 Heart Rate Sensor



**Fig 3.5:** Heart Rate Sensor

Heart beat sensor is intended to give computerized yield of warmth beat when a finger is set inside it. This computerized yield can be associated with ARM straight forwardly to gauge the beats every moment (BPM) rate. It deals with the standard of light adjustment by blood course through finger at each heartbeat.



**Fig 3.6:** Block Diagram of Iclm358

Iclm358 is utilized for heart beat sensor. Its double low power operational intensifier comprises of a super brilliant red drove and light identifier. One will go about as speakers and another will be utilized as comparator. Driven should be super splendid as the light should go through finger and recognized at flip side. At the point when heart pumps a beat of blood through veins, finger turns out to be somewhat more murky so less light came to at the locator. With every heart heartbeat finder flag differs this variety is changed over to electrical heartbeat.

### 3.3.6 MEMS Sensor

MEMS (Micro-Electro-Mechanical Systems) sensors represent a groundbreaking technology that seamlessly integrates miniature mechanical and electrical components on a microscopic scale. These sensors, characterized by their compact size and efficiency, encompass various types, including accelerometers, gyroscopes, magnetometers, pressure sensors, and Inertial Measurement Units (IMUs). Operating on principles like

capacitance changes and piezoelectric effects, MEMS sensors detect, measure, and respond to environmental stimuli. Widely adopted across diverse industries, these sensors find applications in consumer electronics, automotive systems, healthcare devices, industrial machinery monitoring, and environmental monitoring through weather stations and IoT devices. The miniaturization of components, cost-effectiveness due to mass production, and low power consumption contribute to the widespread utilization of MEMS sensors.



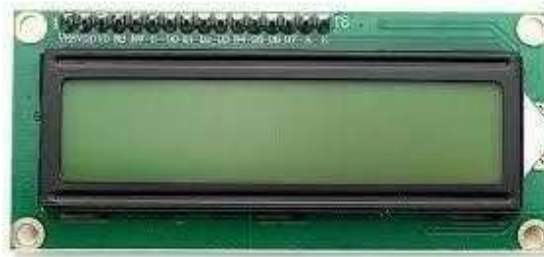
**Fig 3.7:** MEMS Sensor

In the context of fall detection, MEMS accelerometers are utilized to monitor an individual's movements. When a person falls, the accelerometer detects a sudden change in acceleration, as the device experiences a rapid downward motion. The sensor then sends this data to a processing unit, which analyzes the acceleration pattern to determine whether it corresponds to a fall event.

Fall detection algorithms are programmed to differentiate between regular activities and an actual fall. Factors such as the speed, angle, and impact force are considered. If the algorithm identifies a fall, it triggers an alert or alarm, notifying caregivers, emergency services, or relevant personnel about the potential fall.

Integrating MEMS sensors into wearable devices, such as helmets or smartwatches, provides a non-intrusive and effective means of fall detection. In your project, the MEMS accelerometer in the mining helmet enables real-time monitoring of miners' movements, ensuring prompt response in the event of a fall and enhancing overall safety in challenging work environments.

### 3.3.7 LCD Display



**Fig 3.8:** LCD Display

LCD (Liquid Crystal Display) is a type of flat panel display which uses liquid crystals in its primary form of operation. LCDs have a large and varying set of use cases for consumers and businesses, as they can be commonly found in smartphones, televisions, computer monitors and instrument panels. LCDs were a big leap in terms of the technology they replaced, which include light-emitting diode (LED) and gas plasma displays. LCDs allowed displays to be much thinner than cathode ray tube (CRT) technology. LCDs consume much less power than LED and gas-displays because they work on the principle of blocking light rather than emitting it. Where an LED emits light, the liquid crystals in an LCD produces an image using a backlight.

### 3.3.8 ESP8266 Wi-Fi Module

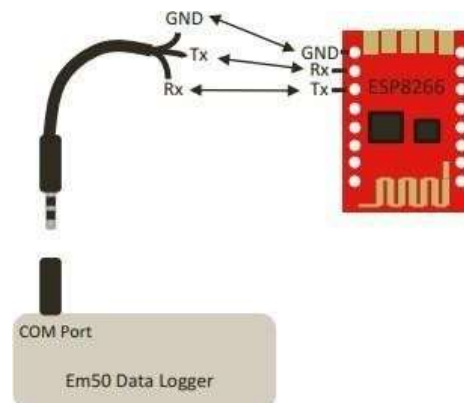


**Fig 3.9:** ESP8266 Wi-Fi Module

ESP8266 was designed by the Chinese company Express if Systems for uses in Internet of Things (IoT) systems. ESP8266 is a complete Wi-Fi system on chip that incorporates a 32-bit processor, some RAM and depending on the vendor between 512KB and 4MB of flash memory. This allows the chip to either function as a wireless adapter

that can extend other systems with Wi-Fi functionality, or as a standalone unit that can by itself execute simple applications. Depending on the specific module variant (ESP-1 to ESP-12 at the time of this thesis) between 0 and 7 General Purpose Input/Output (GPIO) pins are available, in addition to Rx and Tx pins of the UART, making the module very suitable for IoT applications. The Software Development Kit (SDK) provided by Espressif contains a lightweight implementation of a TCP/IP control stack (lwIP) for Wi-Fi communication. The modules house libraries for optional services such as Dynamic Host Configuration Protocol (DHCP), Domain Name System (DNS), JavaScript Object Notation (JSON) and Secure Socket Layer (SSL) libraries for Application-Level programming. It incorporates 802.11 MAC extensions such as 802.11b/g/n/d/e/h/i/k/r that manage signal transmission, encapsulation, encryption, collision management and roaming functionality. The chip generally comes as part of a module, soldered to a Printed Circuit Board (PCB), however it is possible to purchase only the chip itself in order to create a truly custom module. The module variants currently available on the market may include an antenna (PCB or ceramic) or a U-FL connector, a hardware component for serial communication and a myriad of other auxiliary components such as resistors, capacitors and LEDs.

### 3.3.8.1 Serial Communication



**Fig 3.10:** Serial Communication

ESP8266 has multiple peripherals through which it can interface with other modules in a classic embedded fashion. In this section only the setup of the communication link will be presented, since the exact flow of bits to achieve such communication was handled automatically by the module and is therefore deemed of no immediate interest for this thesis. In this case classical UART was used to decode output

and encoding to be send to sensor. Similarly, EM50 data logger has an UART of its own and can do the same thing on its end. Serial asynchronous communication does not require a common clock, however in order for the data to be processed correctly and at right intervals a common baud rate (can be viewed as symbols per second) needs to be set for both devices. The baud-rates supported by ESPs UART component range from 9600 to 921600bps, while the EM50 is configured for 9600bps as default.

### 3.3.9 GSM Module



**Fig 3.11:** GSM Module

The GSM (Global System for Mobile Communications) module stands as a pivotal component in contemporary communication systems, acting as a conduit between electronic devices and cellular networks. This compact module facilitates wireless communication by enabling devices to send and receive various forms of data, including voice calls, text messages, and other information, over global mobile networks.

Incorporating key features such as support for communication protocols like GPRS (General Packet Radio Service), GSM modules seamlessly integrate with applications across diverse domains, from mobile phones to embedded systems and Internet of Things (IoT) devices. An essential aspect of GSM modules is their reliance on Subscriber Identity Modules (SIM cards) to authenticate and authorize access to the mobile network.

Communication with microcontrollers or other devices is established through AT commands, offering a standardized set of instructions for configuration and control.

Beyond supporting voice calls and SMS messaging, GSM modules play a crucial role in data connectivity, particularly in IoT applications, where devices can send and receive data over cellular networks.

In the specific context of our smart helmet system, the GSM module is instrumental in sending emergency SMS messages to registered mobile numbers. This functionality ensures real-time communication and alerts during abnormal conditions, enhancing the overall safety and responsiveness of the system. The integration of GSM technology underscores the system's capability to leverage cellular networks for swift and effective communication, a cornerstone in bolstering workplace safety.

### 3.3.10 GPS Module

The GPS (Global Positioning System) module serves as a cornerstone in our smart helmet system, offering precise location tracking capabilities by interfacing with a network of orbiting satellites. This integral component facilitates real-time determination of accurate geographical coordinates, encompassing latitude, longitude, and sometimes altitude. By continuously receiving signals from multiple satellites, the GPS module ensures dynamic and real-time tracking, providing invaluable insights into the device or user's movement.



**Fig 3.12:** GPS Module

An essential feature of GPS modules is their ability to not only pinpoint location coordinates but also furnish additional data such as speed and direction, contributing to enhanced navigation capabilities. These modules seamlessly integrate with microcontrollers or processing units, allowing devices to incorporate location-based functionalities into their applications. The versatility of GPS technology is evident in its

widespread use across diverse applications, spanning navigation systems in vehicles and smartphones to tracking devices, asset management, and outdoor recreational activities.

In our smart helmet system, the GPS module assumes a pivotal role by enabling the helmet to transmit accurate location details. This functionality proves crucial in emergency situations, as it ensures that alerts sent to registered mobile numbers include vital GPS location information. The integration of GPS technology underscores our commitment to enhancing workplace safety through real-time tracking and effective communication, positioning our system at the forefront of intelligent and responsive safety solutions.

### 3.3.11 APR33A3 Voice Playback Module

APR33A3 Voice play back provides high quality recording and playback with 11 minutes audio at 8 KHz sampling rate with 16-bit resolution. The APR33A3 series C2.x is specially designed for simple key trigger, user can record and playback the message averagely for 1, 2, 4 or 8 voice message(s) by switch, it is suitable in simple interface or need to limit the length of single message.



**Fig 3.13:** APR33A3 Voice Playback Module

The APR33A3 series are powerful audio processor along with high performance audio analog-to-digital converters (ADCs) and digital-to-analog converters (DACs). The aPR33A series are a fully integrated solution offering high performance and unparalleled integration with analog input, digital processing and analog output functionality. The aPR33A series incorporates all the functionality required to perform demanding

audio/voice applications. High quality audio/voice systems with lower bill-of-material costs can be implemented with the aPR33A series because of its integrated analog data converters and full suite of quality-enhancing features such as sample-rate convertor.

**Features:**

- Total 11 minutes of recording time each channel (M0 to M7) having 1.3 minutes of recording time.
- Single chip, high quality voice recording and playback solution.
- User friendly and easy to use operation.
- Non-Volatile flash memory technology, no battery backup required.
- Audio output to drive a speaker or audio out for public address system.
- Can record voice with the help of on-board microphone

**How to Record your Voice:**

- we can use 8 channels (M0 TO M7) each channel having 1.3 minutes recording length.
- Onboard MIC will automatically be used for recording.
- Supply voltage: 12v AC/DC.
- Switch on the board power LED(LD1) will on.
- Put the jumper in the board JP1(REC) Section.
- While in record mode select J5 (M0-M7) to select a channel to record the message.
- Let us assume we want to record message in channel M0, Connect M0 to GND (IN Board J3-VCC, GND).
- Now whatever we speak will be captured by MIC and recorded, status LED(LD2) will on in record mode indicating that chip is currently recording. Once duration is full the LED(LD2) will off mean that segment is full. Now you can disconnect the GND Connection from M0, if before the duration is this connection is removed, then that many seconds are recorded and rest duration is kept empty.

**How to Playback recorder message:**

- Connect the speaker to the board J4 Speaker section.
- Now let us check what we recorded. Remove jumper from JP1(REC) Section
- Now connect the MO(J5) to GND(J3) Section, status LED(LD2) will ON till the recorded sound play in the speaker.

### 3.3.12 Speaker



**Fig 3.14:** Speaker

A loudspeaker (or loud-speaker or speaker) is an electroacoustic transducer; a device which converts an electrical audio signal into a corresponding sound. The most widely used type of speaker in the 2010s is the dynamic speaker, invented in 1924 by Edward W. Kellogg and Chester W. Rice. The dynamic speaker operates on the same basic principle as a dynamic microphone, but in reverse, to produce sound from an electrical signal. When an alternating current electrical audio signal is applied to its voice coil, a coil of wire suspended in a circular gap between the poles of a permanent magnet, the coil is forced to move rapidly back and forth due to Faraday's law of induction, which causes a diaphragm (usually conically shaped) attached to the coil to move back and forth, pushing on the air to create sound waves. Besides this most common method, there are several alternative technologies that can be used to convert an electrical signal into sound. The sound source (e.g., a sound recording or a microphone) must be amplified or strengthened with an audio power amplifier before the signal is sent to the speaker.

### 3.3.13 Battery

Batteries serve as the primary power source for our wheelchair project, providing the necessary electrical energy to drive the motors, operate electronic components, and facilitate wireless communication. Batteries supply the electrical power needed to operate the wheelchair's motorized components, including the DC motors responsible for propulsion and movement control. Unlike wired power sources, batteries offer portability, allowing the wheelchair to operate without being tethered to a fixed power

outlet. This enhances the user's mobility and freedom to navigate different environments.

## 3.4 Software Requirements

- Arduino IDE
- Programming Language
- ThingSpeak

### 3.4.1 Arduino IDE

The Arduino IDE is the software tool used to write, compile, and upload Arduino sketches to an Arduino board. It is a free and open-source software tool that can be downloaded from the Arduino website for Windows, Mac OS X, and Linux operating systems. The Arduino IDE provides a user-friendly interface for creating, editing, and managing Arduino sketches. It includes a text editor with features such as syntax highlighting, auto-indentation, and code completion to make programming easier and faster.

An Arduino sketch from the fig.3.16 is typically written in C or C++ programming languages, and consists of two main functions: `setup()` and `loop()`. The `setup()` function is called once when the board is powered on or reset, and is used to initialize the board and any peripherals connected to it. The `loop()` function is then called repeatedly until the board is turned off or reset, and is used to perform the main tasks of the program.

The Arduino IDE also includes a serial monitor that allows the user to view and send data to the board over a serial connection. This is useful for debugging and communicating with the board during program execution.

Overall, the Arduino IDE is a powerful software tool that provides a user-friendly interface for writing, compiling, and uploading Arduino sketches to the board. It is widely used by hobbyists, students, and professionals for prototyping and developing electronics Projects.

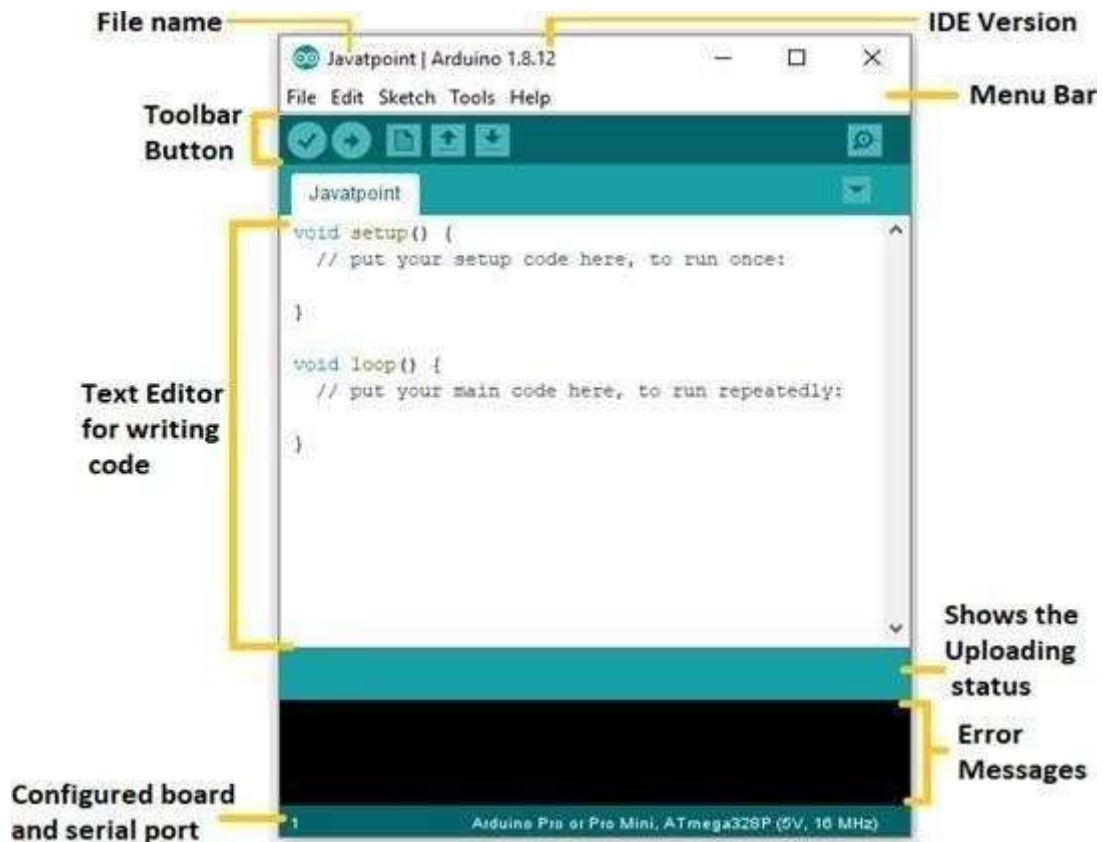


Fig 3.15: Arduino IDE

### 3.4.2 Programming Language

C programming language is a widely used programming language that is often used in embedded systems, including Arduino development. Arduino is an open-source platform that provides hardware and software tools for building and programming microcontroller-based projects.

To use C programming language with Arduino, you would typically use the Arduino Integrated Development Environment (IDE), which is a software tool that provides a user-friendly interface for writing, compiling, and uploading C code to Arduino boards.

### 3.4.3 ThingSpeak



**Fig 3.16:** ThingSpeak Cloud

ThingSpeak is an Internet of Things (IoT) platform developed by MathWorks, designed to facilitate the collection, analysis, and visualization of real-time data from various IoT devices. Users can send data to ThingSpeak using protocols such as HTTP or MQTT, and the platform organizes this information into channels. Each channel represents a specific type of data, and users can create multiple channels to categorize and store diverse sets of information. Fields within channels are defined to store different data points, while additional metadata, such as location details, status, and tags, can be incorporated for context. ThingSpeak provides visualization tools, allowing users to generate charts, graphs, and maps to monitor and analyze their data effectively. Moreover, the platform offers a React feature, enabling users to trigger notifications or actions based on predefined conditions. With an open API, ThingSpeak is compatible with a broad range of IoT devices, fostering easy integration into various projects. Notably, the platform seamlessly integrates with MATLAB, empowering users to apply advanced analytics and custom algorithms to their IoT data through MATLAB scripts. For the latest information, it is advisable to check the official ThingSpeak website or contact MathWorks directly.

### **3.5 Functional Requirements**

- The system must employ sensors to continuously monitor both environmental conditions and the health parameters of mining workers in real-time.
- The smart helmet should be capable of detecting abnormal conditions, such as hazardous gases or sudden falls, through the use of sensors like gas sensors and MEMS accelerometers.
- In case abnormal conditions are detected, the system should generate immediate alerts within the helmet to notify the mining workers of potential dangers.
- The system should have the capability to send notifications to supervisors or relevant personnel, providing them with crucial information about the detected abnormal conditions

### **3.6 Non-Functional Requirements**

#### **3.6.1 Usability**

- The smart helmet must consistently and accurately operate in diverse mining environments and conditions, ensuring that workers can rely on its functionality during critical situations.

#### **3.6.2 Portability**

- The project's portability refers to its ability to send alerts without being restricted by the user's internet access. This ensures that alerts can be communicated seamlessly regardless of the worker's location within the mining site.

#### **3.6.3 Speed**

- The smart helmet is designed for use in mining scenarios, specifically to enhance safety and rescue capabilities for workers during emergencies. Its usability is crucial for providing effective and timely responses to potential risks in the mining environment.

#### **3.6.4 Real-time Responsiveness**

- The system must provide real-time alerts and data updates, facilitating swift responses to emergencies or changing conditions within the mining environment.

### 3.7 Performance

- Advanced sensors, including MEMS, guarantee accurate tracking of environmental conditions, providing real-time data for immediate response and worker safety.
- The integration of cutting-edge communication modules like GSM and GPS enhances the reliability and responsiveness of the alert system, ensuring seamless connectivity in diverse mining environments.
- A robust Wi-Fi module is employed for efficient data retention, enabling future references and data-driven analyses for continuous improvement of safety measures in mining operations.
- The addition of an APR33A3 voice module ensures precise and clear voice alerts, specifying the exact cause during alerts. This feature enhances understanding and enables quick, appropriate responses to identified issues, fostering a safer working environment.

### 3.8 Methodology

To implement this project Iterative model is used. It involves continuous cycle of Planning, Analysis, Implementation and Evaluation, Testing, Deployment, Review, etc., Each cycle produces a segment of development that forms the basis for the next cycle of iterative development.

The iterative model is a software development life cycle (SDLC) approach in which initial development work is carried out based on well-stated basic requirements, and successive enhancements are added to this base piece of software through iterations until the final system is built.

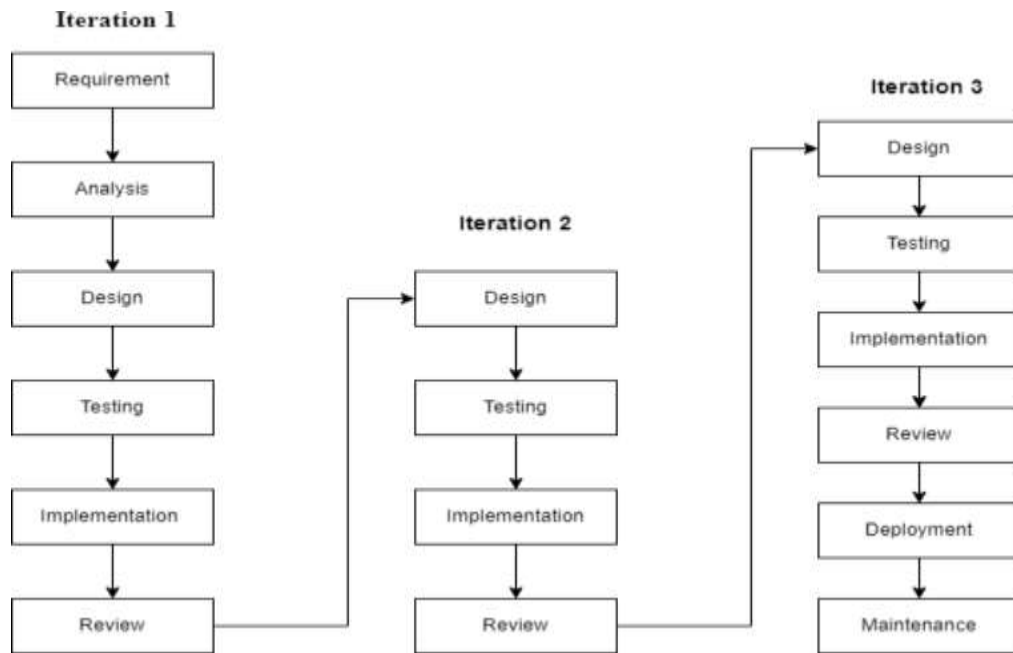


Fig 3.17: Iterative Model

### 3.8.1 Advantages

- It is easily acceptable to ever-changing needs of the project.
- Testing and debugging during smaller iteration are easy.
- A parallel development can plan.
- Risks are identified and resolved during iteration.
- Limited time spent on documentation and extra time on designing

### 3.9 Cost Estimation

S. No	Component	Cost (Rs)	No of pieces required	Total Cost (Rs)
1	Arduino Mega 2560	1600	1	1600
2	DHT 11 Sensor	275	1	275
3	Gas Sensor	270	1	270
4	Infrared Sensor	150	1	150

5	Heart Rate Sensor	140	1	140
6	MEMS Sensor	250	1	250
7	LCD	150	1	150
8	GSM Module	950	1	950
9	GPS Module	650	1	650
10	ESP8266	450	1	450
11	APR33A3	950	1	950
12	Speaker	200	1	200
13	Adapter	400	1	400
14	Battery	250	1	250
	<b>Total Cost</b>			<b>6685</b>

Table 3.1: Cost Estimation

### 3.10 Time Estimation

S. No	Activity	Duration
1	Domain & Title	1 Week

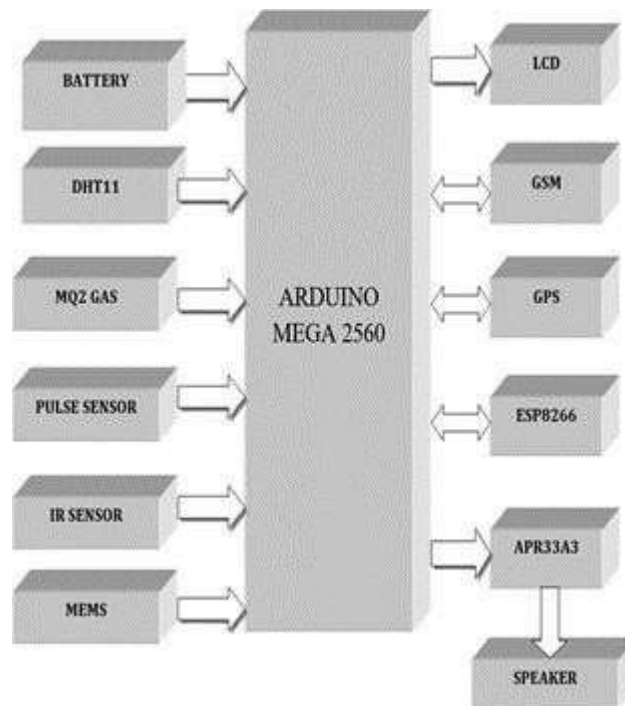
2	Literature Survey	1 Week
3	Requirements Specification	1 Week
4	Planning	1 Week
5	Design	1 Week
6	Gathering Requirements	1 Week
7	Software Development	1 Week
8	Hardware Development	2 Weeks
9	Testing	1 Week
10	Implementation	1 Week

**Table 3.2:** Time Estimation

## CHAPTER 4

### DESIGN

#### 4.1 System Architecture



**Fig 4.1** Block Diagram

The block diagram of the voice and key-controlled wheelchair system outlines the key functional components and their interactions. At the core of the system is the user interface, represented by a mobile app, which allows users to choose between key control or voice control modes for operating the wheelchair. This selection is transmitted wirelessly via a Bluetooth module to the Arduino microcontroller, which serves as the central processing unit of the system. The Arduino receives and interprets the user commands and generates corresponding signals to control the motor drivers. These motor drivers regulate the power supplied to the DC motors, translating the control signals into precise movements of the wheelchair. Additionally, the block diagram includes ultrasonic sensors, which provide feedback to the Arduino regarding the wheelchair's surroundings, enabling obstacle detection and collision avoidance. This comprehensive system architecture ensures efficient and intuitive control of the wheelchair, enhancing user mobility and safety.

## 4.2 Flow Chart

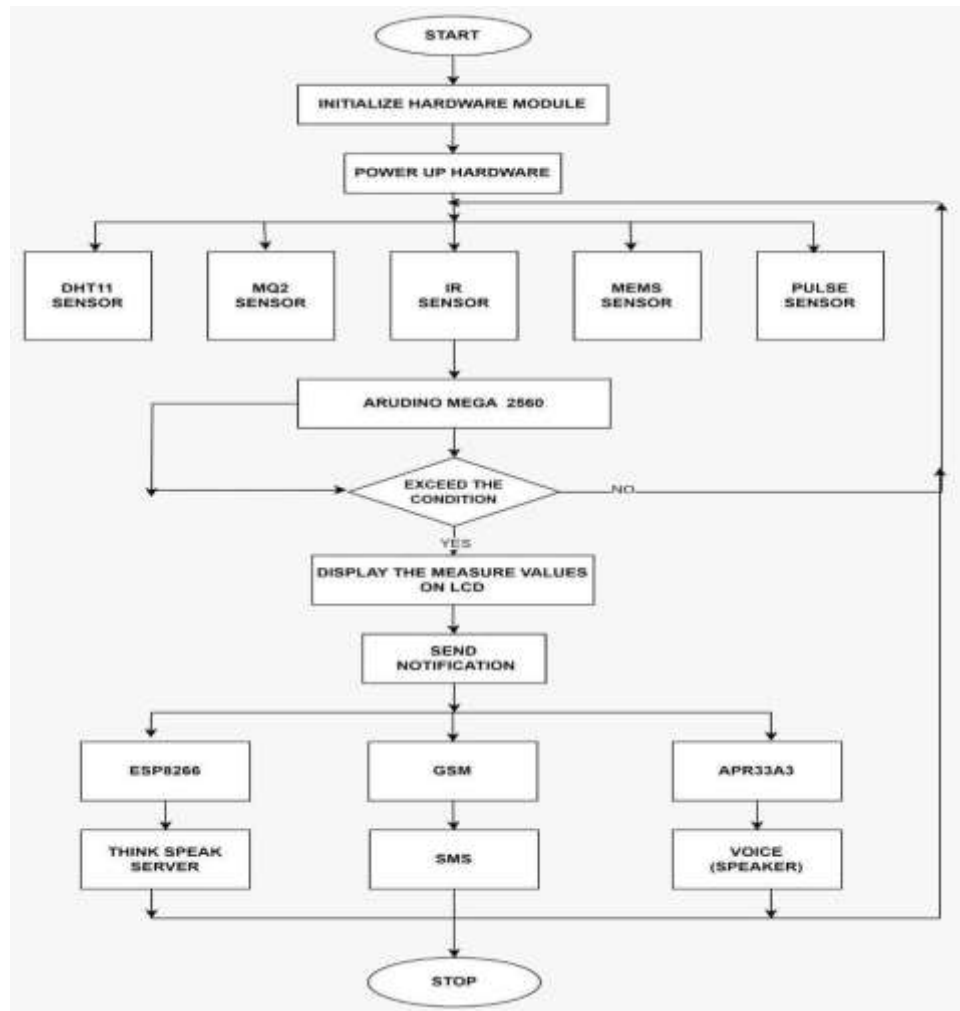


Fig 4.2 Flow Chart

The flowchart provides a comprehensive insight into the operational intricacies of the smart helmet system designed for mining safety. The journey commences with the initiation phase, where all hardware components, including the pivotal Arduino Mega microcontroller, an array of sensors, and versatile communication modules, are primed for action. This initialization sets the stage for a dynamic and interconnected system that aims to ensure the well-being of mining workers in challenging environments.

As the hardware powers up, the flowchart elegantly bifurcates into dedicated branches for each crucial sensor embedded in the smart helmet. These sensors, namely the DHT11 for temperature and humidity, MO2 for gas detection, IR for helmet usage, MEMS for fall detection, and the Pulse sensor for heart rate monitoring, collectively form a robust sensory network. Each sensor plays a vital role in assessing specific aspects of

the mining environment and the wearer's physiological parameters.

The system then meticulously evaluates readings from each sensor, gauging whether they breach predefined threshold levels indicative of potential risks. Should a sensor reading exceed the established safety thresholds, the system follows a cascading sequence of actions. It includes the real-time display of the measured value on the helmet's LCD screen, providing immediate feedback to the wearer. Simultaneously, the system initiates notifications, offering a versatile approach through options like GSM for SMS alerts and ESP8266 Wi-Fi for cloud-based communication.

Conversely, if sensor readings fall within acceptable limits, the system seamlessly proceeds through the evaluation without triggering alarms. This cyclical and continuous process ensures perpetual monitoring of the mining environment and the miners' well-being. By seamlessly integrating cutting-edge technology, the smart helmet system stands as a testament to innovation in occupational safety, providing real-time insights and actionable alerts in potentially hazardous scenarios.

# CHAPTER 5

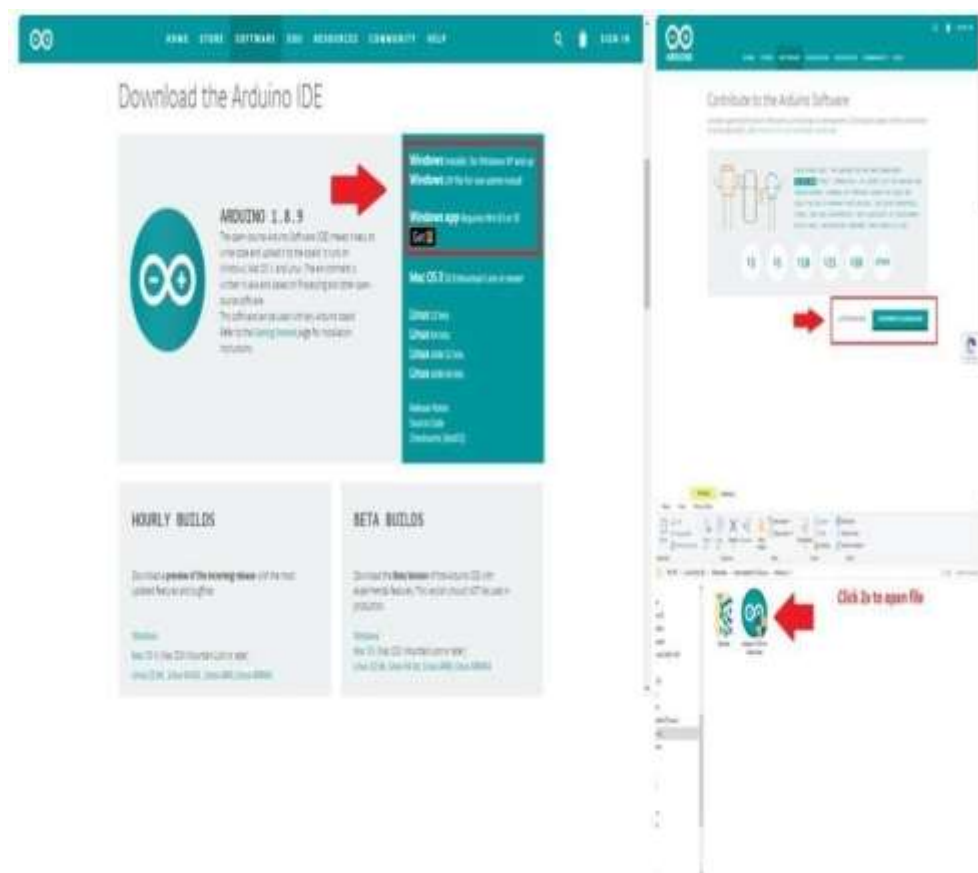
## IMPLEMENTATION

### 5.1 Software Implementation

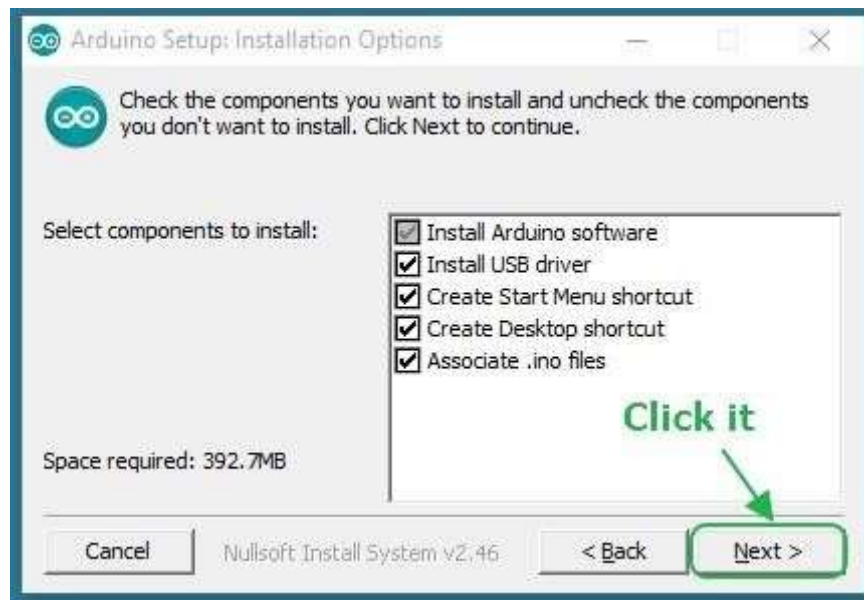
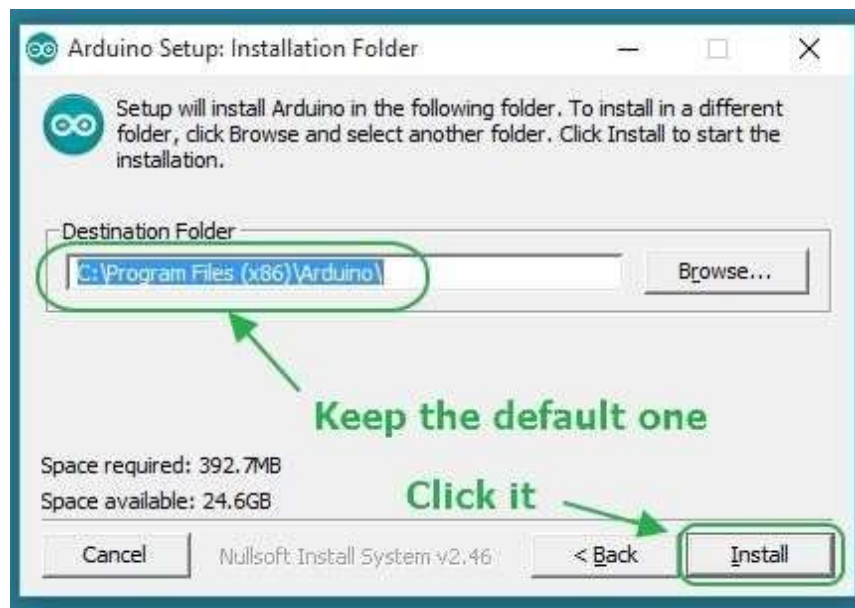
#### 5.1.1 Installation of Arduino UNO IDE

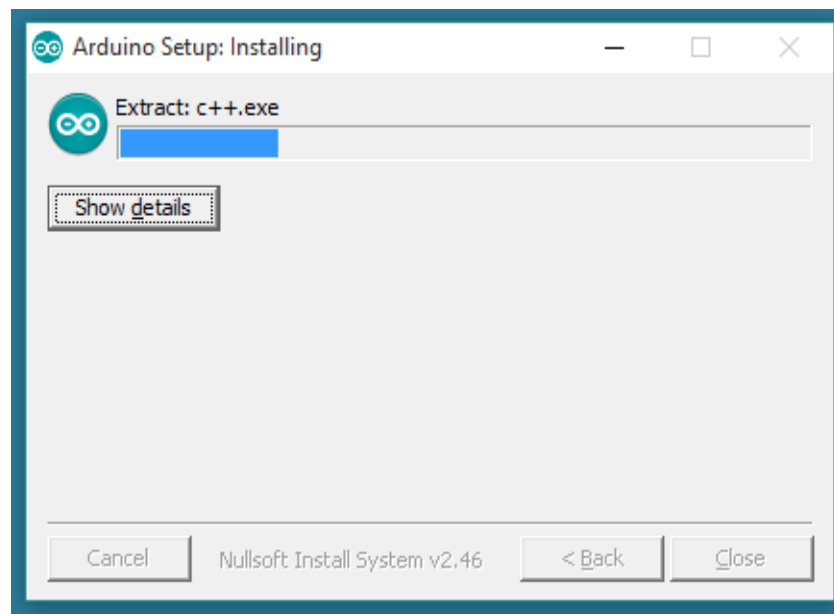
To install Arduino UNO IDE on your Windows PC, follow the next instructions:

**STEP 1:** Download file Arduino IDE

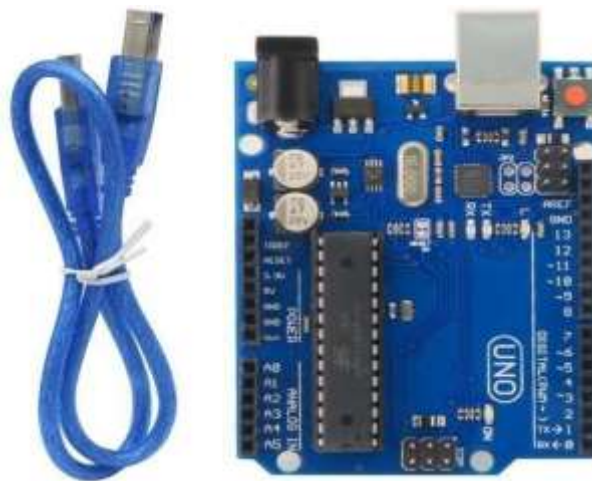


**Fig 5.1:** Download Arduino Uno IDE on Windows

**STEP 2: Installation option****Fig 5.2:** Arduino Setup-Installation Options**STEP 3: Installation folder****Fig 5.3:** Arduino Setup Installation Folder

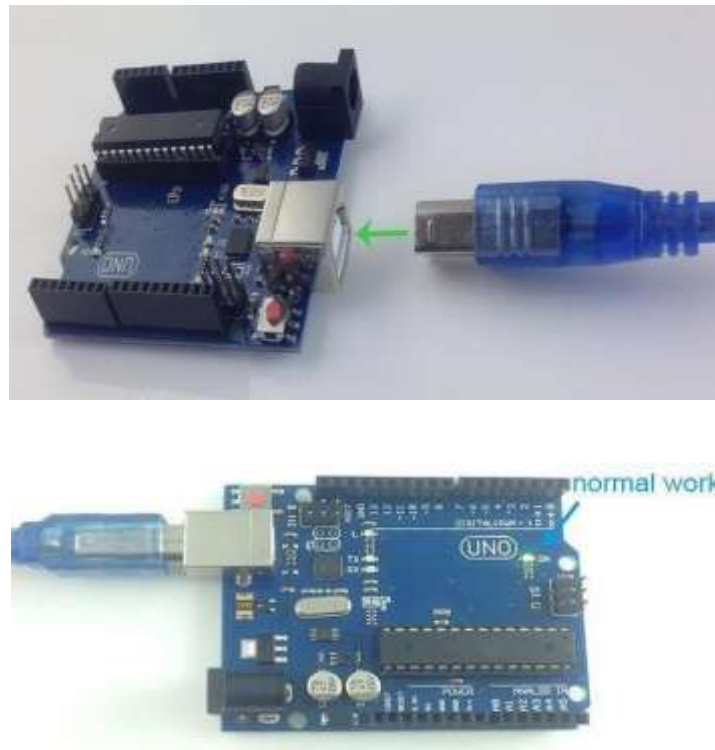
**STEP 4:** Installing process**Fig 5.4:** Arduino Setup-Installing**STEP 5:** Get an Arduino Mega and USB cable

In this instructional exercise, you're utilizing an Uno R3. You additionally require a standard USB link (A fitting to B plug): the kind you would associate with a USB printer, for instance.

**Fig 5.5:** USB cable and Arduina Mega board

**STEP 6:** Connect the board

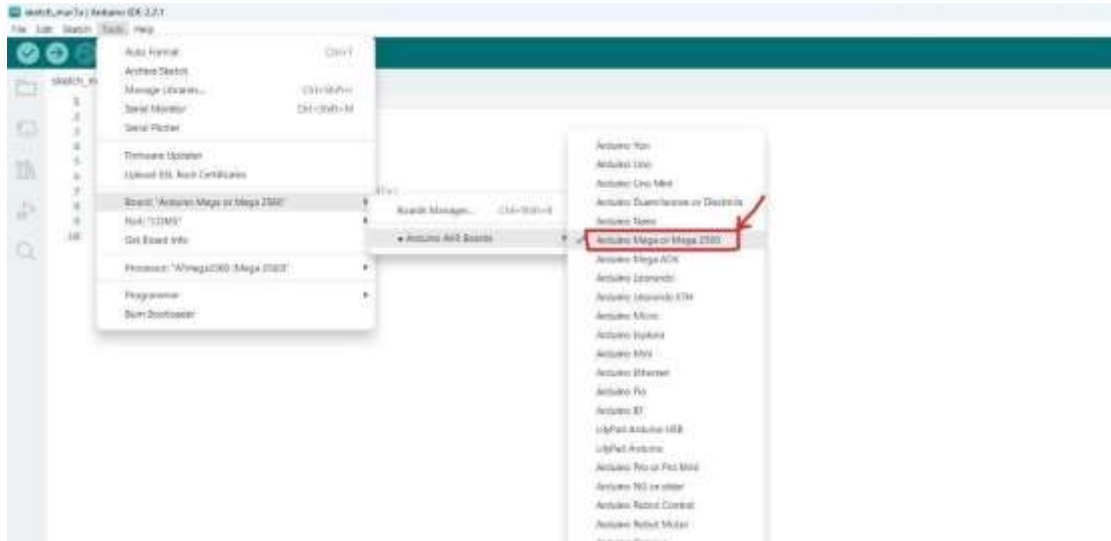
The USB association with the PC is important to program. The USB association with the PC is important to program the board and not simply to control it up. The Uno and Mega consequently draw control from either the USB or an outside power supply. Associate the board to your PC utilizing the USB link.



**Fig 5.6:** Represents how to connect USB cable with Mega board

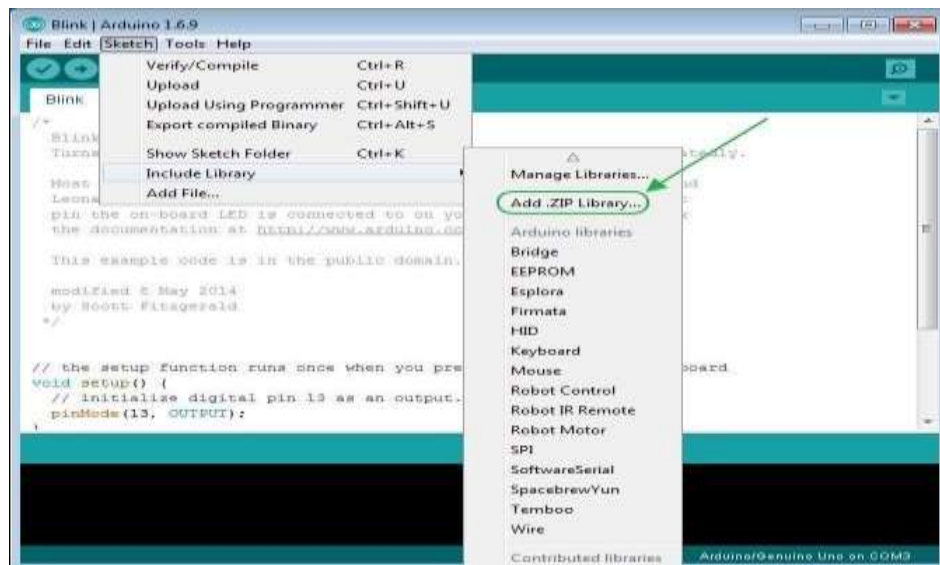
**STEP 7: Select your board**

You'll need to select the entry in the Tools > Board menu that corresponds to your Arduino board.



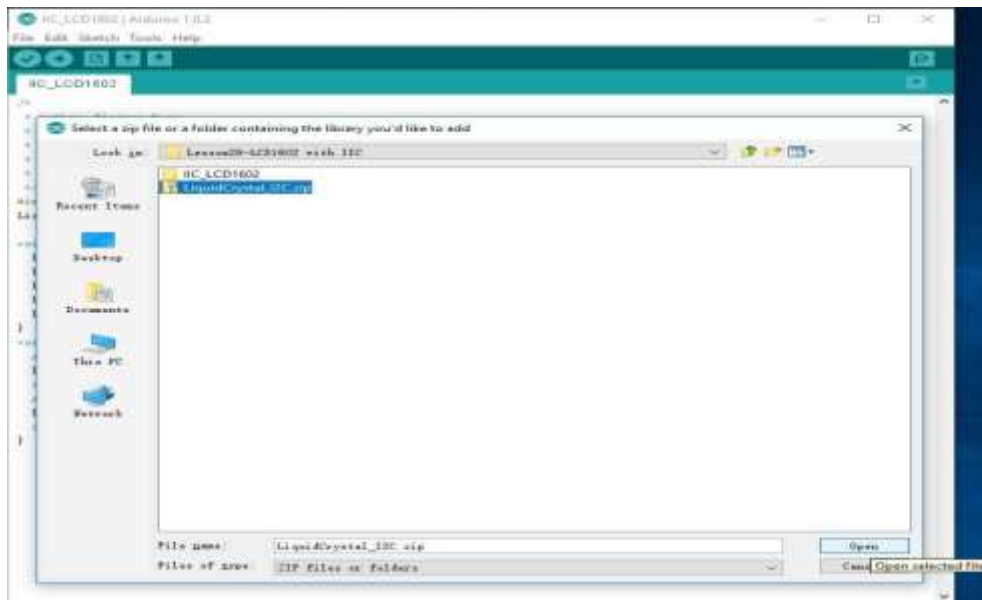
**Fig 5.7: Path to Select Board**

**STEP 8: Add library file: Sketch>Include Library>Add.ZIP Library**



**Fig 5.8: Path to Add Zip Library**

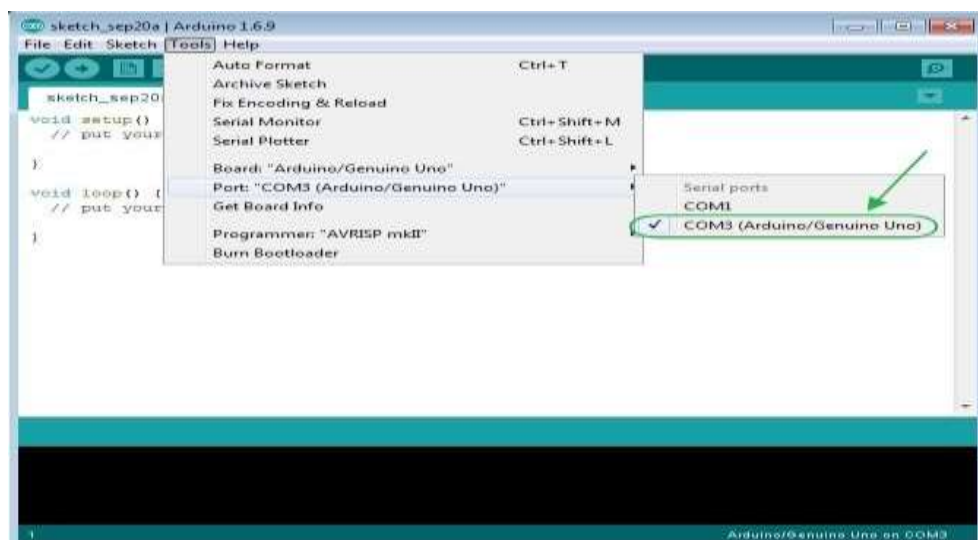
**STEP 9:** Select your library file compression package on the demo code file, as follows



**Fig 5.9:** Selecting a Zip File

**STEP 10:** Select your serial port

Select the serial gadget of the board from the Tools | Serial Port menu. This is probably going to be COM3 or higher (COM1 and COM2 are generally held for equipment serial ports). To discover, you can detach your board and re-open the menu; the passage that vanishes ought to be the Arduino board. Reconnect the board and select that serial port.



**Fig 5.10:** Path to Select Serial Port

## 5.1.2 Source Code

```
#include <DHT11.h>
#include<LiquidCrystal.h>
#include <SoftwareSerial.h>
#include "DFRobotDFPlayerMini.h"
DFRobotDFPlayerMini player;
LiquidCrystal lcd(2, 3, 4, 5, 6, 7);
DHT11 dht11(A6);
const int pulse = A0;
const int gas = A2;
const int xaxis = A10;
const int yaxis = A11;
const int ir = 8;
float millivolt,voltage;
float tempertureC,temp;
int p, i, cl, x, y, pl, h;
float val;
int gas1;
int temp1, hum;
#define DEBUG 1
String network = "project";
String password = "project1234";
#define IP "184.106.153.149" // IP address of thingspeak.com
String GET = "GET/update?key=HRC0CN3IOGNVLAFAQ";
//S2XWZDGUM3QGVKIV
char input [30];
char bsinput[30];
String rfid;
int cnt;
#include <TinyGPS.h>
TinyGPS gps;
float flat=0, flon=0;
```

```
void setup()
{
    Serial.begin(9600);
    Serial1.begin(115200);
    Serial2.begin(9600);
    Serial3.begin(9600);
    if (player.begin(Serial2)) {
        Serial.println("OK");
        player.volume(30);
        // Play the "0001.mp3" in the "mp3" folder on the SD card
        player.playMp3Folder(1);
    } else {
        Serial.println("Connecting to DFPlayer Mini failed!");
    }
    lcd.begin(16,2);
    lcd.clear();
    lcd.setCursor(0,0);
    pinMode(xaxis,INPUT);
    pinMode(yaxis,INPUT);
    pinMode(pulse,INPUT);
    pinMode(gas,INPUT);
    pinMode(ir,INPUT);
    lcd.begin(16,2);
    lcd.print("SMART HELMENT");
    lcd.setCursor(0,1);
    lcd.print("FOR MINING ");
    delay(1000);
    lcd.clear();
    lcd.setCursor(0,0);
    lcd.print("TURN ON HOTSPOT");
    delay(2000);
    lcd.clear();
    lcd.setCursor(0,0);
```

```
    lcd.print("SET SSID:project");
    lcd.setCursor(0,1);
    lcd.print("pwd:project1234");
    setupEsp8266();
    delay(1000);
    Serial3.println("AT");
    delay(500);
    Serial3.println("AT+CNMI=2,2,0,0,0");
    delay(500);
    Serial3.println("AT+CMGF=1");
    delay(1000);
    Serial3.println("AT+CMGF=1");
    welcome_note();
    //send_sms();
}
void loop()
{
    read_gps();
    Serial.println(i);
    //dht11
    // Read the humidity from the sensor.
    int humidity = dht11.readHumidity();
    // Read the temperature from the sensor.
    int temperature = dht11.readTemperature();
    // If the temperature and humidity readings were successful, print them to the
    serial monitor.
    if (temperature != -1 && humidity != -1) {
        lcd.setCursor(2,0);
        lcd.print(temperature);
        lcd.setCursor(6,0);
        lcd.print(humidity);
    } else {
        // If the temperature or humidity reading failed, print an error message
```

```
        Serial.println("Error reading data");
    }
    temp1 = temperature;
    hum = humidity;
    // Wait for 2 seconds before the next reading.
    // pulse
    p = analogRead(pulse);
    if (p < 50) {
        p1 = 0;
    } else {
        p1 = p;
    }
    p1 = map(p1,0,1023,0,120);
    lcd.setCursor(10,0);
    lcd.print(p1);
    if (p1 > 100) {
        send_sms(1);
        Serial.println("WEAR HELMENT");
        player.playMp3Folder(4);
        delay(3000);
        Serial.println("WEAR HELMENT");
        player.playMp3Folder(4);
        delay(3000);
        Serial.println("WEAR HELMENT");
        player.playMp3Folder(4);
        delay(3000);
        Serial.println("sent");
    }
    //ir
    i = digitalRead(ir);
    if (i == LOW) {
        lcd.setCursor(15,1);
        lcd.print("N");
    }
}
```

```
    send_sms(2);
    h = 1;
    Serial.println("WEAR HELMENT");
    player.playMp3Folder(6);
    delay(3000);
    Serial.println("WEAR HELMENT");
    player.playMp3Folder(6);
    delay(3000);
    Serial.println("WEAR HELMENT");
    player.playMp3Folder(6);
    delay(3000);
    Serial.println("sent");
} else {
    lcd.setCursor(15,1);
    lcd.print("Y");
    h = 0;
    delay(500);
}
// mems
x = analogRead(xaxis);
y = analogRead(yaxis);
lcd.setCursor(2,1);
lcd.print(x);
lcd.setCursor(7,1);
lcd.print(y);
if ((x > 380) | (x < 320) | (y > 380) | (y < 320)) {
    delay (2000);
    send_sms (3);
    Serial.println("WEAR HELMENT");
    player.playMp3Folder(5);
    delay(3000);
    Serial.println("WEAR HELMENT");
    player.playMp3Folder(5);
```

```
        delay(3000);
        Serial.println("WEAR HELMENT");
        player.playMp3Folder(5);
        delay(3000);
        Serial.println("sent");
        lcd.setCursor(15,1);
        lcd.print("p");
        delay(1000);
    }
    // gas
    gas1 = analogRead(gas);
    lcd.setCursor(13,0);
    lcd.print(gas1);
    delay(1000);
    if (gas1 > 350) {
        send_sms(4);
        Serial.println("WEAR HELMENT");
        player.playMp3Folder(3);
        delay(3000);
        Serial.println("WEAR HELMENT");
        player.playMp3Folder(3);
        delay(3000);
        Serial.println("WEAR HELMENT");
        player.playMp3Folder(3);
        delay(3000);
        Serial.println("sent");
    }
    if (temperature > 40) {
        send_sms(5);
        Serial.println("WEAR HELMENT");
        player.playMp3Folder(1);
        delay(3000);
        Serial.println("WEAR HELMENT");
```

```

        player.playMp3Folder(1);
        delay(3000);
        Serial.println("WEAR HELMENT");
        player.playMp3Folder(1);
        delay(3000);
        Serial.println("sent");
    }
    if (humidity > 50) {
        send_sms(6);
        Serial.println("WEAR HELMENT");
        player.playMp3Folder(2);
        delay(3000);
        Serial.println("WEAR HELMENT");
        player.playMp3Folder(2);
        delay(3000);
        Serial.println("WEAR HELMENT");
        player.playMp3Folder(2);
        delay(3000);
        Serial.println("sent");
    }
    cl = cl + 1;
    //Serial.print("cnt = ");
    // Serial.println(cl);
    if (cl > 5) {
        Serial.println("AT");
        lcd.setCursor(11,1);
        lcd.print("cloud update");
        updateTemp (String (temperature), String (humidity), String (gas1),
        String (p1),String(h),String(x),String(y));
        cl = 0;
        lcd.setCursor(10,1);
        lcd.print(" HEL:    ");
    }

```

```
}  
void send_sms(int p)  
{  
    Serial3.println("AT");  
    //Serial.println("AT");  
    delay(500);  
    Serial3.println("AT+CMGF=1");  
    delay(500);  
    Serial3.println("AT+CMGS=\"+917794844779\"\\r");  
    // Replace x with mobile number917892606752  
    delay(1000);  
    if(p==1) {  
        Serial.println("p=1");  
        Serial3.println("PULSE RATE ELEVATED");  
    }  
    if(p==2) {  
        Serial.println("p=2");  
        Serial3.println("MINER HELMENT IS REMOVED");  
    }  
    if(p==3) {  
        Serial.println("p=3");  
        Serial3.println("SUDDEN FALL IS DETECTED");  
    }  
    if(p==4) {  
        Serial.println("p=4");  
        Serial3.println("HAZARDOUS GAS DETECTED");  
    }  
    if(p==5) {  
        Serial.println("p=5");  
        Serial3.println("ALERT HIGH TEMPERATURE DETECTED");  
    }  
    /*if(p==6)  
    {
```

```

Serial.println("p=6");
Serial3.print("SPIKE IN HUMIDITY LEVEL DETECTED");
  */
  Serial3.print("TEMPERATURE:");
  Serial3.print(temp1);
  Serial3.print("HUMIDITY:");
  Serial3.print(hum);
  Serial3.print("PULSE");
  Serial3.print(p1);
  Serial3.print("HELMENT=");
  Serial3.print("YES");
  Serial3.print("X-XAIS");
  Serial3.print(x);
  Serial3.print("Y-XAIS");
  Serial3.print(y);
  Serial3.print("GAS");
  Serial3.print(gas1);
  Serial3.println("TROUBLE AT
https://www.google.com/maps/place/14.7452, 7.6896");
  //14.7452° N, 77.6896° E
  /*Serial.println("TROUBLE AT https://www.google.com/maps/place/");
  Serial.println(String(flat,6));
  Serial.println(String(flon,6));*/
  delay(1000);
  delay(1000);
  Serial3.println("");
  delay(100);
  Serial3.println((char)26); // ASCII code of CTRL+Z
  delay(1000);
}
void setupEsp8266()
{
  Serial1.flush();

```

```
Serial1.println(F("AT+RST"));
delay(7000);
if (Serial1.find("OK")) {
    if (DEBUG) {
        //Serial.println("Found OK");
        // Serial.println("Changing espmode");
    }
    Serial1.flush();
    changingMode();
    delay(5000);
    Serial1.flush();
    connectToWiFi();
} else {
    if (DEBUG) {
        //Serial.println("OK not found");
    }
}
connectToWiFi();
}

bool changingMode()
{
    Serial1.println(F("AT+CWMODE=1"));
    if (Serial1.find("OK")) {
        if (DEBUG) {
            //Serial.println("Mode changed");
        }
        return true;
    }
    else if (Serial1.find("NO CHANGE")) {
        if (DEBUG) {
            //Serial.println("Already in mode 1");
        }
        return true;
    }
}
```

```

    } else {
        if (DEBUG) {
            //Serial.println("Error while changing mode");
        }
        return false;
    }
}
bool connectToWiFi()
{
    if (DEBUG) {
        // Serial.println("inside connectToWiFi");
    }
    String cmd = F("AT+CWJAP=\\");
    cmd += network;
    cmd += F("\\,\\");
    cmd += password;
    cmd += F("\\");
    Serial1.println(cmd);
    delay(15000);
    if (Serial1.find("OK")) {
        if (DEBUG) {
            //Serial.println("Connected to Access Point");
        }
        return true;
    } else {
        if (DEBUG) {
            // Serial.println("Could not connect to Access Point");
        }
        return false;
    }
}
void updateTemp(String variable1,String variable2,String variable3,String
variable4,String variable5,String variable6,String variable7)

```

```

{
    String cmd = "AT+CIPSTART=\\"TCP\\,\\"";
    cmd += IP;
    cmd += "\",80";
    Serial1.println(cmd);
    delay(3000);
    if(Serial1.find("Error")){
        if (DEBUG){
            //Serial.println("ERROR while SENDING");
        }
        return;
    }
    cmd = GET + "&field1=" + variable1 + "&field2=" + variable2 + "&field3="
        + variable3 + "&field4=" + variable4 + "&field5=" + variable5 + "&field6="
        + variable6 + "&field7=" + variable7 + "\r\n";
    Serial1.print("AT+CIPSEND=");
    Serial1.println(cmd.length());
    Delay (13000);
    if (Serial1.find(">")) {
        Serial1.print(cmd);
        if (DEBUG) {
            // Serial.println("Data sent");
        }
    } else {
        Serial1.println("AT+CIPCLOSE");
        if (DEBUG) {
            //Serial.println("Connection closed");
        }
    }
}

void welcome_note()
{
    lcd.clear();
    lcd.setCursor(0,0);

```

```

    lcd.print("T: H: P: G:");
    lcd.setCursor(0,1);
    lcd.print("X: Y: HEL: ");
}
void read_gps()
{
    bool newData = false;
    unsigned long chars;
    unsigned short sentences, failed;
    for (unsigned long start = millis(); millis() - start < 1000;) {
        while (Serial.available()) {
            char c = Serial.read();
            if (gps.encode(c))
                newData = true;
        }
    }
    if (newData){
        unsigned long age;
        gps.f_get_position(&flat, &flon, &age);
    }
}

```

### STEP 7: Upload the program

Presently, essentially tap the "Transfer" catch in the earth. Hold up a couple of moments - you should see the RX and TX leds on the board blazing. On the off chance that the transfer is fruitful, the message "Done transferring." will show up in the status bar.



**Fig 5.11:** Path to Upload and Compile

## CHAPTER 6

### TESTING

#### 6.1 Testing Approach

The testing of the Smart Helmet project will be conducted systematically to ensure its functionality and reliability. It will be divided into two main stages: software testing and hardware testing. Each stage will involve specific features to be tested, testing tools, and procedures.

#### 6.2 Features to be Tested

The following features of the Smart Helmet project will be tested:

##### **Environmental Sensors:**

- Gas sensor: Ensure it detects hazardous gases accurately.
- Temperature and humidity sensor: Verify it monitors environmental conditions effectively.

##### **Worker Condition Monitoring:**

- Heart rate sensor: Validate its accuracy in tracking the worker's heart rate.
- Infrared sensor: Ensure it confirms continuous helmet usage.
- MEMS sensor: Verify fall detection capabilities.

##### **Alerting System:**

- APR33A3 voice module: Confirm it provides clear and specific alerts.
- GSM module: Ensure timely transmission of alert messages.
- GPS module: Validate accurate location tracking during emergencies.

#### 6.3 Testing Tools and Environment

For testing the Smart Helmet project, the following tools and environment will be utilized:

- Arduino IDE: To test the software functionality and code execution.

- Power supply: To provide power to the helmet system during testing.
- Testing environment: A simulated mining environment or controlled laboratory setting to replicate real-world conditions.

## 6.4 Test Cases

In this section, we will define test cases to validate the functionality of the system:

### 6.4.1 Inputs

The inputs for testing the Smart Helmet project include:

- Power supply: Ensure sufficient power is provided to all components.
- Simulated environmental conditions: Test various scenarios to validate sensor responses.
- Worker conditions: Mimic different worker scenarios to verify sensor accuracy.

### 6.4.2 Expected Output

The expected outputs of the Smart Helmet project include:

- Accurate detection and monitoring of environmental conditions.
- Real-time tracking and monitoring of worker health parameters.
- Timely and clear alert messages during hazardous events.

### 6.4.3 Testing Procedure

The testing procedure for the Smart Helmet project involves the following steps:

#### Software Testing:

- Upload the code to the Arduino or microcontroller.
- Simulate various scenarios to test sensor functionality.
- Verify the alerting system by triggering different events.

#### Hardware Testing:

- Assemble the helmet with all components properly connected.
- Test each sensor individually to ensure proper functioning.

- Conduct integrated testing to validate overall system performance.

**Field Testing:**

- Deploy the Smart Helmet in a real mining environment.
- Monitor its performance in detecting and responding to actual hazards.
- Collect feedback from miners for further improvements.

By following this testing approach, the Smart Helmet project can be thoroughly evaluated for its effectiveness in enhancing miner safety and well-being.

## CHAPTER 7

### RESULT

In the Smart Helmet project, the core functionality revolves around the integration of various sensors and components into a wearable helmet designed to enhance safety and monitoring for mining workers. The system incorporates specialized sensors such as gas sensors, temperature and humidity sensors, accelerometers, gyroscopes, infrared sensors, and heart rate sensors. These sensors work collectively to monitor environmental conditions and the well-being of the wearer in real-time. For instance, gas sensors detect hazardous gases, temperature, and humidity sensors monitor environmental parameters, while accelerometers and gyroscopes track worker movements and detect falls. The data collected by these sensors is processed by a microcontroller embedded within the helmet. Upon detecting abnormal conditions or emergencies, the microcontroller triggers alerts and notifications, ensuring timely response and assistance for the wearer. Additionally, the helmet features a voice interface module for delivering alerts and instructions, further enhancing communication and safety in mining environments. Overall, the Smart Helmet project aims to provide comprehensive safety measures and real-time monitoring to safeguard mining workers' well-being.



**Fig: 7.1** Smart Helmet

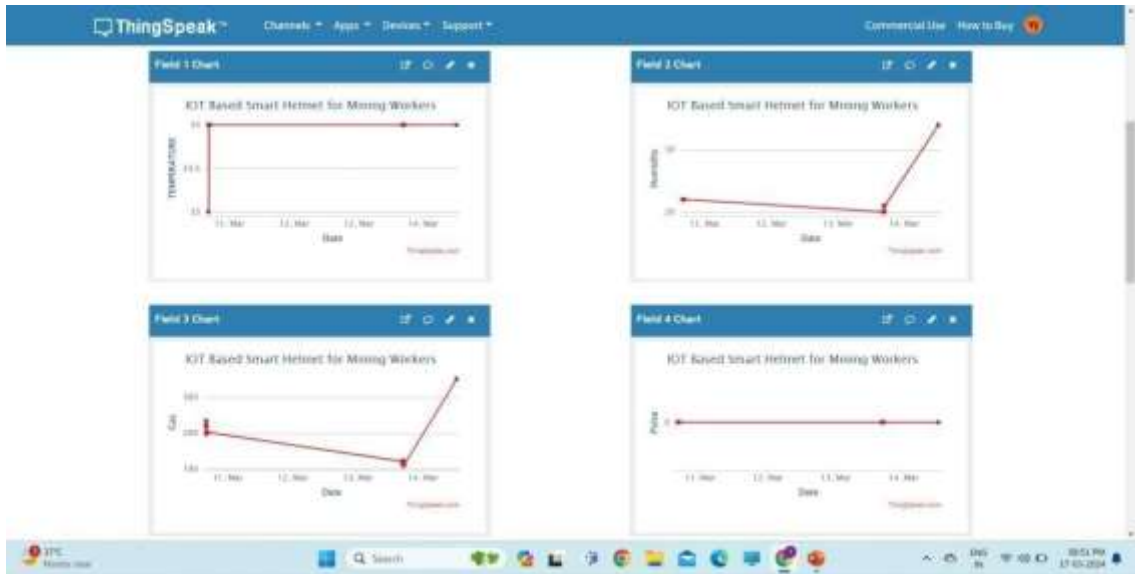


Fig: 7.2 ThingSpeak sensor data Analysis through data provided by temperature, Humidity, gas and pulse sensor

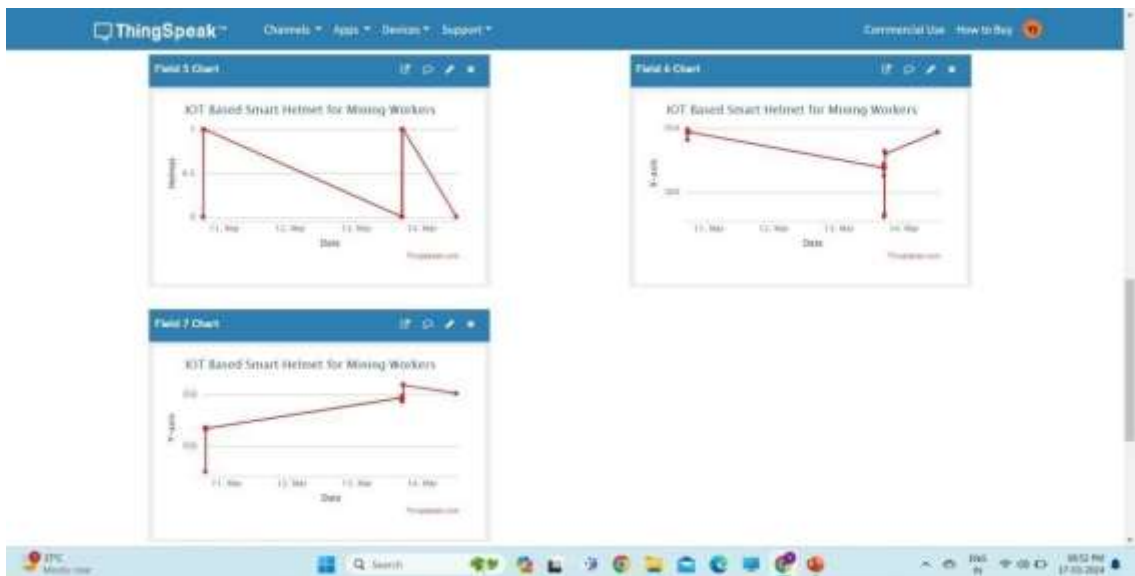


Fig: 7.3 ThingSpeak Sensor Data Analysis through data provided by IR, MEMS Sensor

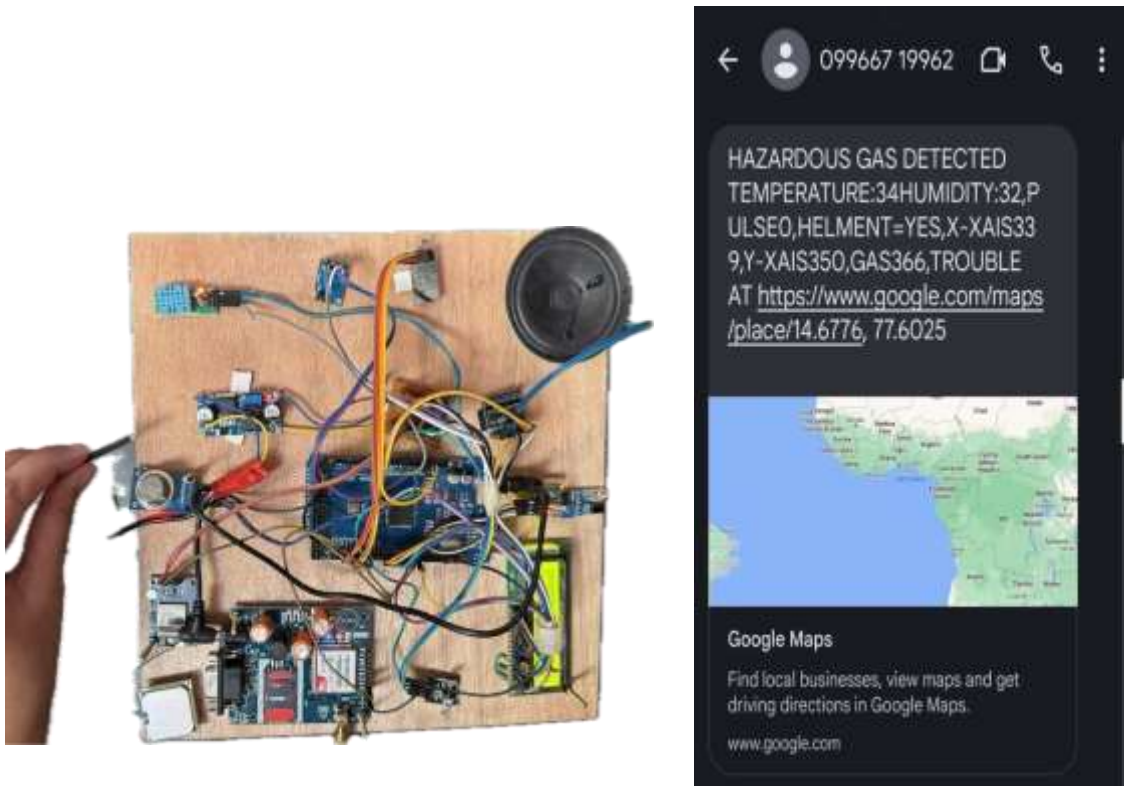


Fig: 7.4 Alert Due to Hazardous gas detection

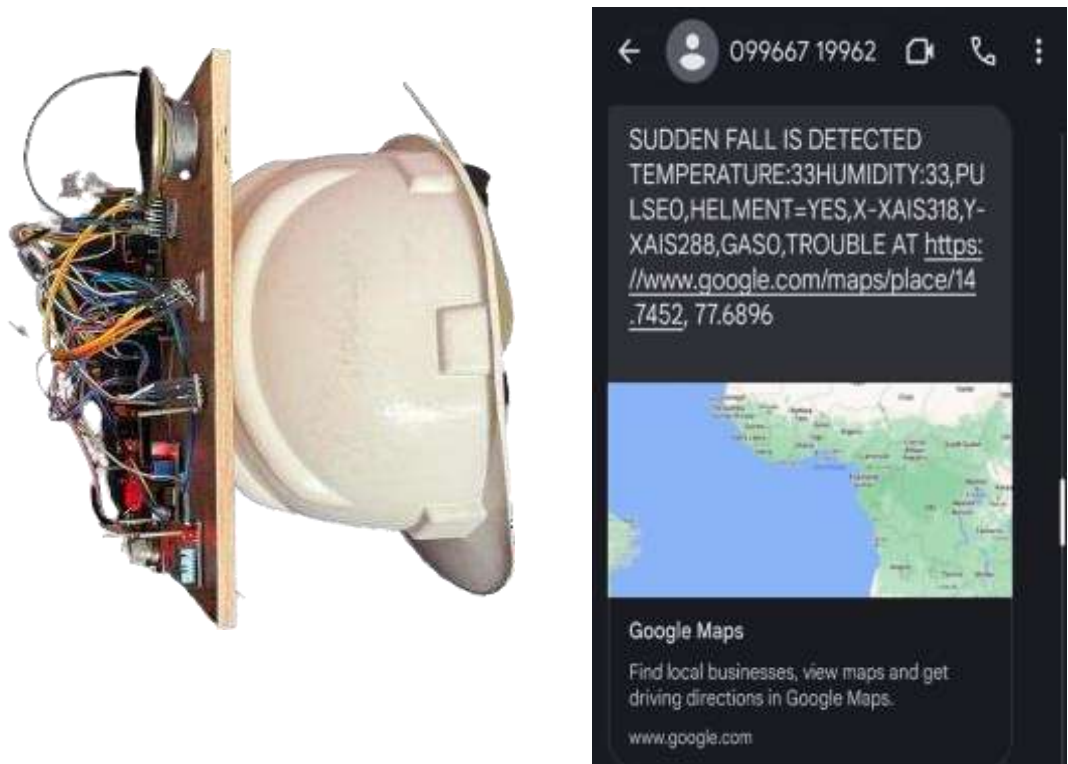
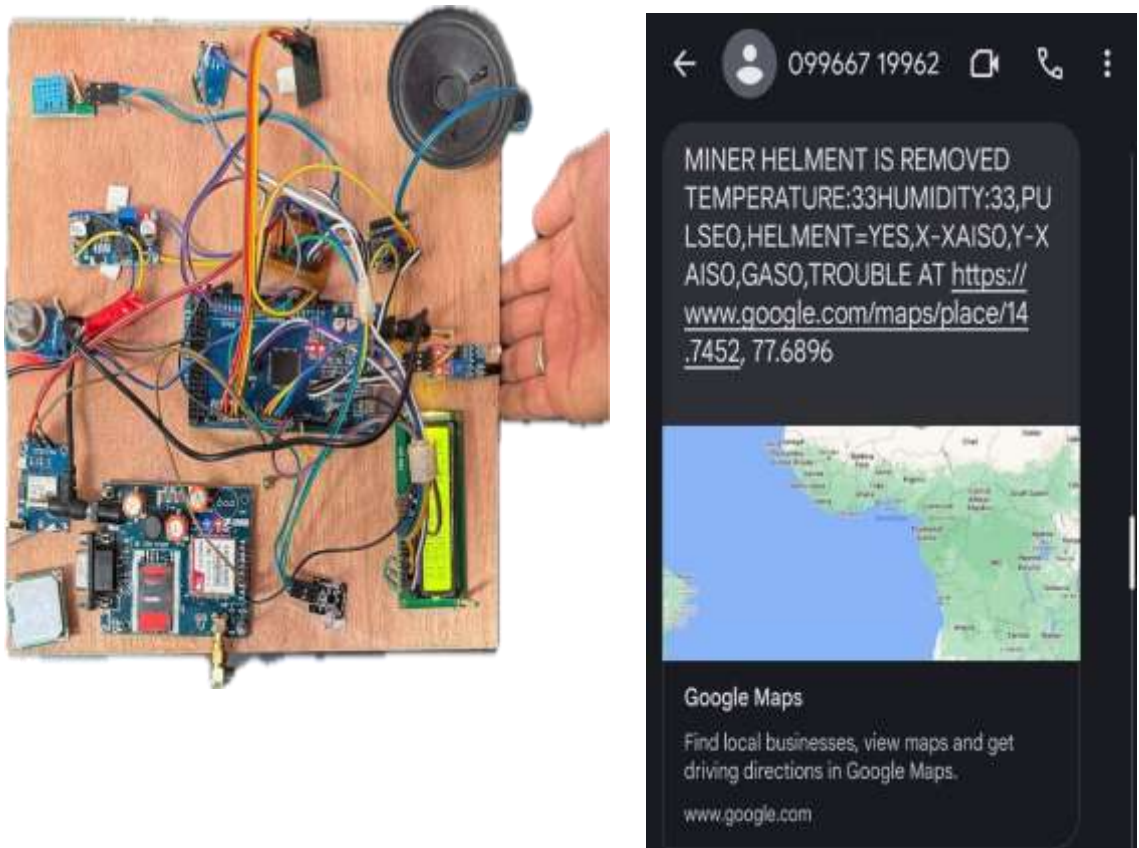


Fig: 7.5 Alert due to Fall Detection



**Fig: 7.6** Alert Due to Miner Removed Helmet



**Fig: 7.7** Output on Lcd

## CHAPTER 8

### CONCLUSION

In conclusion, the integration of IoT-based smart helmets in the mining industry marks a significant advancement in ensuring the safety and well-being of miners. The existing system, relying on traditional helmets, demonstrates certain limitations, particularly in maintaining environmental awareness, fall detection, and specifying the exact cause during alerts. The proposed smart helmet system addresses these gaps by integrating various sensors, including a gas sensor and temperature/humidity sensor for environmental monitoring, ensuring protection against hazardous conditions. Additionally, the helmet utilizes MEMS sensors, an IR sensor, and a heart rate sensor to monitor workers' conditions. Moreover, the system is enhanced by an efficient alerting system, incorporating a voice interface module (APR33A3) and robust communication system by GSM and GPS modules. To facilitate data retention for future references and predictive analyses, a Wi-Fi module is employed to store information on ThingSpeak. This holistic system represents an advanced solution that elevates workplace safety through real-time monitoring, precise alerts, and insights derived from data analysis. Beyond safety enhancement, this comprehensive solution also contributes to improved communication, emergency response, and overall operational efficiency within mining endeavors.

## REFERENCES

- [1] Sowmya T, SrinivasaRao G, Sruthi Ch, Tanuja , I.Bhavya, M.Sindhu Priya, “**Smart Helmet For Mining Workers**”, Journal of Engineering Sciences, Volume. 14, pp. 0377-9254, 2023.
- [2] Jeya Seelan S, Krittika J, Cerene Eunice Getsiah C, Arunachalam B, “**IoT Based Intelligent Helmet for Miners**”, International Journal of Electrical Engineering and Technology, Volume. 12, pp. 123-128, March. 2021.
- [3] GAO junyao, GAO xueshan, ZHU wei, ZHUjianguo, WEI boyu. ”**Coal Mine Detect and Rescue Robot Design and Research**” IEEE 2008.[4] Jong C. Wang, Yan Ting Lin, Huei Teng Jheng, Jyun Sian Wu and Ruei Jhe Li, “Object Tracking for Autonomous Biped Robot” IEEE 2010
- [4] Manikandan S, Arun Francis G. Mithya V, Kamal C, Dhilip Kumar S, Hariprasath R, Sankar P, “**A Smart Helmet for Air Quality and Hazardous Event Detection for theMining Industry**”, International Journal of Innovative Technology and Exploring Engineering, Volume. 8, pp. 2278-3075, October. 2019.
- [5] Shruti P. Borkar<sup>1</sup>, V. B. Baru, “**IoT Based Smart Helmet for Underground Mines**”, International Journal of Research in Engineering, Science and Management, Volume. 1, pp. 2581-5782, September. 2018
- [6] A.P. Squelch, “**Virtual reality for mine safety training in South Africa,**” Thes Journal of The South African Institute of Mining and Metallurgy, pp. 209-216, July 2001.
- [7] X.B. Jiang, “**ZigBee technology and its applications**” [J]. Low-voltage apparatus, 2005.
- [8] Z.J.Tian, “**Digital Mobile Voice Communication Encode and Voice Communication Designed**” [J]. China Coal, 2007.

# Mine Safe: IOT Based Smart Helmet for Mining Workers

Praneel Kumar Peruru<sup>1, a)</sup>, Yashaswini Jawalkar<sup>2, b)</sup>, Pavan Peddinti<sup>3, c)</sup>,  
Tufel Basha Mogal<sup>4, d)</sup>, Divya Pommala<sup>5, e)</sup>

*Author Affiliations*

<sup>1, 2, 3, 4, 5</sup> Srinivasa Ramanujan Institute of Technology Anantapur, Andhra Pradesh, 515001, India

*Author Email*

<sup>a)</sup> Corresponding author: [praneel.cse@srit.ac.in](mailto:praneel.cse@srit.ac.in)

<sup>b)</sup> [204g1a05c5@srit.ac.in](mailto:204g1a05c5@srit.ac.in)

<sup>c)</sup> [204g1a0571@srit.ac.in](mailto:204g1a0571@srit.ac.in)

<sup>d)</sup> [204g1a05b3@srit.ac.in](mailto:204g1a05b3@srit.ac.in)

<sup>e)</sup> [194g1a0528@srit.ac.in](mailto:194g1a0528@srit.ac.in)

**Abstract** Mining is recognized as one of the most hazardous occupations globally. The death rate of mining workers at mining sites is increasing day by day. Considering this, we cannot simply avoid mining because it plays a vital role. Instead, an alternative solution is to implement safety measures and continue operations in mines. To ensure the well-being of workers and protect them from potential health hazards, we propose a smart and adaptable helmet for workers. This advanced helmet incorporates a range of specialized sensors to monitor both environmental conditions and workers health. Environmental monitoring is facilitated by Gas sensor, Temperature and Humidity sensor, ensuring that workers are protected from hazardous conditions. Simultaneously, the helmet employs Accelerometer and Gyroscope sensors, IR sensor, Heart Rate sensor to monitor worker's conditions. Furthermore, an integrated emergency button enables miners to request help swiftly, triggering alerts that pinpoint their exact location. Instead of relying on traditional loud alarms, the helmet communicates crucial information to the miner through a voice interface, offering real-time updates and guidance during emergency situations. The developed helmet system is primarily intended to improve the working environment in mines and ensure worker safety

**Keywords:** Smart Helmet, Accelerometer and Gyroscopesensor, Voice interface module

## INTRODUCTION

In the contemporary landscape of industrial innovation and technological advancement, the integration of smart solutions has become increasingly pivotal across various sectors. One such domain that has witnessed transformative developments is the mining industry, a cornerstone of economic prosperity for nations worldwide. This paper delves into the critical intersection of technology and mining safety, addressing the multifaceted challenges faced by miners and proposing an innovative approach to enhance their well-being and security. Mining is indispensable for the economy of every country, providing numerous opportunities across various industries. The benefits generated by this industry contribute significantly to local communities by processing the materials it offers. However, working in mining poses specific health and safety risks, especially in challenging or unpredictable conditions. The mining industry is complex, involving intricate operations conducted within tunnels, underground passages, and other challenging environments. The intricate nature of mining operations presents a variety of risk variables that may compromise the well-being and security of miners. The Chasnala mining tragedy in the Indian state of Jharkhand, close to Dhanbad, is a heartbreaking example. Almost 372 miners' lives were almost lost in this tragedy, which is regarded as one of the deadliest in the history of the mining industry.

Miners frequently encounter unnoticed environmental factors such as changes in pressure and temperature. The lives of excavators are in grave danger when they crash with big things like hard rocks or mining equipment. The inhalation of dangerous gases poses a substantial risk of injury to miners and is considered a severe threat. Miners are cut off from outside communication under such circumstances. Recognizing the need for proactive safety measures, this paper explores the development of a smart protective helmet system designed to detect and respond to hazardous events in real-time. Beyond event detection, the system encompasses environmental monitoring, GPS tracking, and the provision of

oxygen enhancements to mitigate risks associated with toxic gases. The proposed system not only addresses the immediate safety concerns but also serves as a forward-looking initiative to ensure the well-being of miners in the evolving landscape of the mining industry.

Moreover, considering the rising prominence of the mining sector in certain regions, such as Pakistan with its substantial coal reserves, the paper discusses the challenges faced in making sure that miners are safe. The convergence of technological solutions, such as microcontroller-based monitoring systems and the Internet of Things (IoT), presents as a pivotal strategy to overcome these challenges and fortify the safety infrastructure within the mining industry.

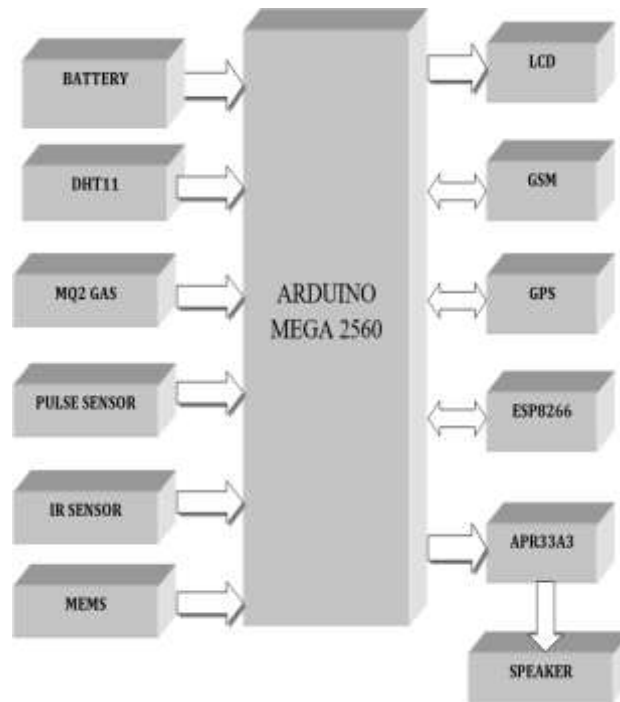
In navigating this discourse, the aim is to contribute to the ongoing dialogue on mining safety by presenting an integrated and forward-thinking approach. By leveraging cutting-edge technologies and innovative solutions, we strive to redefine the safety paradigm for miners, fostering a safer, more secure environment for those working at the heart of economic prosperity.

## **LITERATURE SURVEY**

- a. T. Sowmya, G. SrinivasaRao, Ch. Sruthi, I. Tanuja, I. Bhavya, M. Sindhu Priya proposed A system which uses a variety of sensors to monitor workplaces. It incorporates the DHT11 sensor for environmental temperature and humidity monitoring and the MQ2 sensor for recognizing dangerous substances. The Smart helmet is equipped with a WiFi module for Internet of Things connectivity, a GPS location tracker, and a GSM modem for delivering emergency SMS messages. This system is particularly used for detecting safety at workplaces but not for the workers.
- b. Jeya Seelan S, Krittika J, Cerene Eunice Getsiah C, Arunachalam B introduces an Intelligent Helmet system equipped with various sensors and utilizing Zigbee protocol for real-time monitoring of hazardous conditions. The proposed system integrates multiple sensors, including temperature, methane gas, and heart rate, with a Zigbee mesh network ensuring reliable data transmission for timely alerting and emergency response. GAO junyao,
- c. GAO xueshan, ZHU wei, ZHUjianguo, WEI boyu proposed a wearable IoT-enabled jacket specifically crafted to safeguard individuals employed in coal mines, often subjected to potential hazards. This prototype is engineered to detect multiple factors such as harmful chemicals, the heartbeat of a coal miner, underground conditions, and the miner's GPS location. The collected data is intended to be transmitted accessing an ever-changing internet protocol using an encrypted Wi-Fi channel.

## **PROPOSED SYSTEM**

We have developed an advanced protective helmet embedded with a sophisticated array of sensors designed for comprehensive detection and analysis. The primary sensor categories include environmental sensors and sensors for monitoring the condition of workers. Within the environmental sensor suite, we employed a gas sensor to detect hazardous gases, along with temperature and humidity sensors to detect abnormal fluctuations in temperature and humidity. Additionally, for monitoring the worker's condition, we've integrated sensors such as a pulse sensor for tracking the worker's heart rate, an infrared sensor to ensure continuous helmet usage, and a MEMS sensor for detecting sudden falls.



**FIGURE 1:** Block Diagram



**FIGURE 2:** Flow Chart

These sensors consistently monitor both environmental conditions and the well-being of workers. When abnormal conditions arise, and the tracked values exceed predefined thresholds, the system triggers a sound alert. Unlike traditional buzzers, we employ an APR33A3 voice module which provides a sound alert that specifies the exact cause. Along with the localized alerts, the system sends alert messages to registered mobile numbers, including GPS location details facilitated by GSM and GPS modules. To ensure data retention for future references and predictive analyses, a WiFi module is utilized to store information on ThingSpeak. This

a comprehensive system signifies a cutting-edge solution that enhances workplace safety through real-time monitoring, accurate alerts, and data-driven insights.

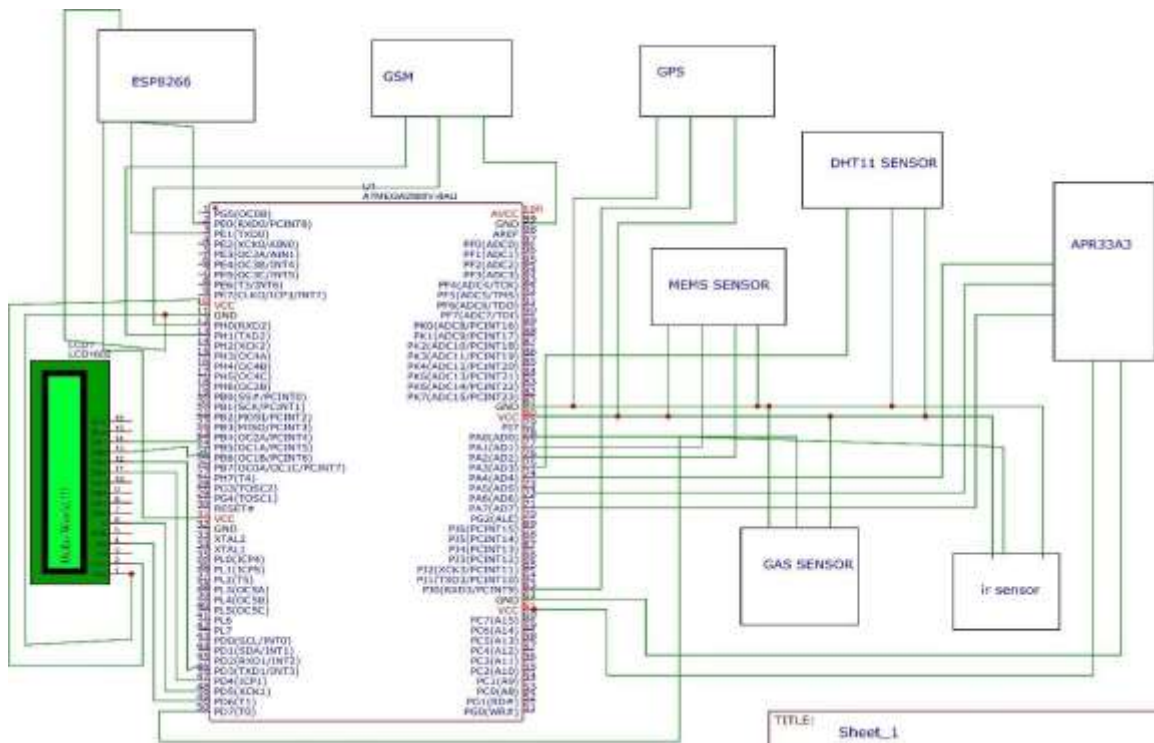


FIGURE 3: Circuit Diagram

## HARDWARE AND DESCRIPTION

### A. ARDUINO MEGA 2560:

The Arduino Mega 2560, a powerful microcontroller board, is utilized in our project because of its adaptability. It effectively manages a variety of sensors that are essential to mining safety. It allows for a wide range of sensor inputs and has 54 digital and 16 analog I/O connections, which ensures environmental and health monitoring in deep mines. It can store and process data from several sensors with its 256 KB flash memory. Multiple UART ports on the Mega 2560 allow for multi-mode connection, which makes it easier to integrate different communication protocols into our smart helmet system. It is the best option for our project's complex sensor integration and communication requirements due to its adaptability and broad capabilities.



FIGURE 4: Arduino Mega 2560 Board

### B. MQ-2 SENSOR

The MQ-2 gas sensor is used because of its reputation for being highly versatile in detecting a wide range of gases, such as hydrogen, butane, propane, methane, alcohol, and smoke. When our smart helmet system is integrated with it, real-time monitoring of underground mining environments is made possible. This improves safety measures by quickly identifying harmful gasses and notifying personnel.



**FIGURE 5: MQ-2 Sensor**

The MQ-2 sensor's smooth integration with our microcontroller makes it possible to detect gases effectively and reliably, which is essential for protecting the health and safety of mine worker.

### **C. DHT11 SENSOR**



**FIGURE 6: DHT11 Sensor**

The DHT11 Sensor uses a thermistor and a humidity-sensing element to measure temperature and humidity. The resistance of the humidity-sensing element fluctuates with humidity levels, whereas the resistance of the thermistor changes with temperature. By measuring these resistances and converting them into digital impulses, the sensor gives precise temperature and humidity readings that can be monitored in real time.

### **D. IR SENSOR**



**FIGURE 7: IR Sensor**

Infrared sensor is a crucial part of the helmet usage verification system in underground mining since it both generates and absorbs infrared light. It enhances safety procedures by confirming workers are wearing helmets through the analysis of reflected signals. The use of the IR sensor improves adherence to safety guidelines and makes a substantial positive impact on the general health and safety of mining workers.

### **E. HEART RATE SENSOR:**

The heart rate sensor, which uses photoplethysmography, is essential to our underground mining project's ongoing health monitoring. With its real-time heart rate data provided by an integrated system, we can better prioritize worker well-being and respond quickly to possible health risks. The use of heart rate sensors makes the workplace safer and greatly improves the general health and safety of mining workers.



**FIGURE 8:** Heart Rate Sensor

#### **F. MEMS SENSOR:**



**FIGURE 9:** MEMS Sensor

Fall detection systems rely heavily on MEMS sensors, especially accelerometers. These tiny sensors, which are incorporated into our System, detect acceleration variations, making it possible to recognize sudden, unusual movements that could be signs of a fall. Through the use of MEMS sensors, our system improves underground mining safety by quickly identifying and addressing possible fall occurrences, hence promoting the general well-being of mining workers.

#### **G. ESP8266 MODULE**



**FIGURE 10:** ESP8266 Wifi Module

ESP8266 Wifi Module has inbuilt TCP/IP protocol stack, the self-contained System-on-Chip (SOC) ESP8266 WiFi Module makes it simple for any microcontroller to connect to WiFi networks. Due to its versatility, it can either run a program on its own behalf or assign WiFi networking responsibilities to a separate application processor. The ESP8266 module has pre-programmed software with an AT command set that makes it easy to connect to Arduino devices and offers WiFi functionality similar to that of a WiFi shield. In the field of Internet of Things (also known as IoT) development, it is a well-liked and accessible option due to its affordability and broad community support. This module is widely used in many different projects and applications because of its cost, versatility, and vast user base.

## H. GSM MODULE

A GSM modem is a device that operates using a SIM card, similar to those found in mobile phones. It is designed to connect to a mobile operator's network, enabling communication via that network. When integrated into a system, such as the smart helmet, the GSM modem serves as a means of communication. The smart helmet controller can use the GSM modem to send and receive messages, including SMS and MMS. This functionality allows the smart helmet system to transmit alerts, notifications, or other information using the mobile network, enhancing its communication capabilities



**FIGURE 11:** GSM Module

## I. GPS MODULE

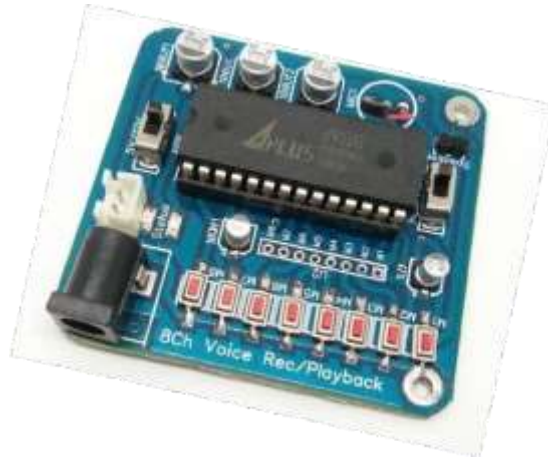


**FIGURE 12:** GPS Module

A GPS module is a specialized device that integrates with electronic systems to provide accurate location information based on signals from GPS satellites. It includes a GPS receiver to determine precise geographical coordinates. In the smart helmet system, this module is crucial for real-time tracking, emergency response coordination, and overall site management, enhancing safety in large or complex mining environments.

## J. APR33A3 MODULE

The APR33A3 is a voice recording and playback integrated circuit module. It is designed to record and reproduce audio messages or sounds. In the context of the smart helmet system, it is utilized to provide specific alerts in response to detected events. Unlike traditional alert systems with generic buzzers, this module allows the system to articulate precise information about the nature of the alert, it enhances communication and awareness for the miners. It brings a more sophisticated and informative aspect to the alerting system, contributing to improved safety in mining operations



**FIGURE 13:** Voice Playback Module

PARAMETERS	UNIT	THRESHOLD
Gas Concentration	PPM	2000-5000
Temperature	°C	40
Humidity	%	60
IR	analog	HIGH - LOW
Heart Rate	BPM	100
MEMS	g	1.5 - 2.5

**TABLE 1:** Threshold values for Various Sensor

### CONCLUSION

In conclusion, the integration of IoT-based smart helmets in the mining industry marks a significant advancement in ensuring the safety and well-being of miners. The existing system, relying on traditional helmets, demonstrates certain limitations, particularly in maintaining environmental awareness, fall detection, and specifying the exact cause during alerts. The proposed smart helmet system addresses these gaps by integrating various sensors, including a gas sensor and temperature/humidity sensor for environmental monitoring, ensuring protection against hazardous conditions. Additionally, the helmet utilizes MEMS sensors, an IR sensor, and a heart rate sensor to monitor workers' conditions. Moreover, the system is enhanced by an efficient alerting system, incorporating a voice interface module (APR33A3) and robust communication system by GSM and GPS modules. To facilitate data retention for future references and predictive analyses, a WiFi module is employed to store information on ThingSpeak. This holistic system represents an advanced solution that elevates workplace safety through real-time monitoring, precise alerts, and insights derived from data analysis. Beyond safety enhancement, this comprehensive solution also contributes to improved communication, emergency response, and overall operational efficiency within mining endeavors.

## REFERENCES

- [1] Sowmya T, SrinivasaRao G, Sruthi Ch, Tanuja , I.Bhavya, M.Sindhu Priya, “Smart Helmet For Mining Workers”, Journal of Engineering Sciences, Volume. 14, pp.0377-9254, 2023.
- [2] Jeya Seelan S, Krittika J, Cerene Eunice Getsiah C, Arunachalam B, “IoT Based Intelligent Helmet For Miners”, International Journal of Electrical Engineering and Technology, Volume. 12, pp. 123-128, March. 2021.
- [3] GAO junyao, GAO xueshan, ZHU wei, ZHUjianguo, WEI boyu. ”Coal Mine Detect and Rescue Robot Design and Research” IEEE 2008.[4] Jong C. Wang, Yan Ting Lin, Huei Teng Jheng, Jyun Sian Wu and Ruei Jhe Li, “Object Tracking for Autonomous Biped Robot” IEEE 2010
- [4] Manikandan S, Arun Francis G. Mithya V, Kamal C, Dhilip Kumar S, Hariprasath R, Sankar P, “A Smart Helmet for Air Quality and Hazardous Event Detection for the Mining Industry”, International Journal of Innovative Technology and Exploring Engineering, Volume. 8, pp. 2278-3075, October. 2019.
- [5] Shruti P. Borkar1 , V. B. Baru, “IoT Based Smart Helmet for Underground Mines”, International Journal of Research in Engineering, Science and Management, Volume. 1, pp. 2581-5782, September. 2018.
- [6] A.P. Squelch, “Virtual reality for mine safety training in South Africa,” Thes Journal of The South African Institute of Mining and Metallurgy, pp. 209-216, July 2001.
- [7] X.B. Jiang, ZigBee technology and its applications [J]. Low-voltage apparatus, 2005 .Z.J. Tian, Digital Mobile Voice Communication Encode and Voice Communication Designed [J]. China Coal, 2007.
- [8] H.M. Zhu and L. Zhang, The Design of Warp Tension Embedded Intelligent Control System Based on  $\mu$ C/OS and ARM [J]. Mechanical & Electrical Engineering Magazine, 2006 .
- [9] X. Zhang, X.J. Qiao and E. Liu, Design of High Precision Instrument for Measuring Temperature, Humidity & Dew Point[J]. Instrument Technique and Sensor, 2006 .
- [10] L. Ma and H. Guo, Smart Sensor for Underground Coal Mine Based on ZigBee Protocol [J]. Instrument Technique and Sensor, 2007 .
- [11] Implementation of Smart Safety Helmet for Coal Mine Workers. In IEEE International Conference on Power Electronics. Intelligent Control and Energy Systems. Jorhat, India, ICPEICES.
- [12] Vargas Hernández, J. G., & Plascencia, M. D. L. R.(2017). Application of the IndustryBased Theory the Case of Mexican Company Cemex. Management & Administration (IMPACT: JMDGMA), 1(2), 31-44.
- [13] Sanchit Gupta and Rashmi Vashisth, 2017. IMPLEMENTATION AND ANALYSIS OF SMART HELMET. In IEEE International Conference on Signal Processing, Computing and Control (ISPCC 2k17). Solan, India, Sep21-23, 2017, IEEE.
- [14] Chang, W. Y., & Chang, P. C. (2018). Application of Radial Basis Function Neural Network, to Estimate the State of Health for LFP Battery. International Journal of Electrical and Electronics Engineering (IJECE), 7(1), 1- 6.
- [15] raveen Kulkarni and Sangam, “Smart System for Hazardous Event Detection and Evaluation in Mining Industries,”. International Journal of Innovative Research in Electrical, Electronics, Instrumentation and Control Engineering, 5th Vol 3rd Issue, 2017.
- [16] SHARMA, S., & KUMAR, G. (2016). A dual Wideband Stair Shape Microstrip Patch Antenna for C & X Band. International Journal of Electronics and Communication Engineering (IJECE), 5(4), 1- 8.

# CERTIFICATION



**CHAITANYA BHARATHI**  
**INSTITUTE OF TECHNOLOGY**  
(UGC-AUTONOMOUS)  
PRODDATUR  
Vidyanagar, Proddatur, YSR Kadapa (Dist.),  
Andhra Pradesh 516360



ICIAET-24  
Proceedings

## International Conference on Innovative Approaches in Engineering & Technology (ICIAET-24)

5<sup>th</sup> & 6<sup>th</sup> April 2024

Organized by Department of Electrical & Electronics Engineering

### Certificate of Appreciation

This certificate is awarded to Dr./Mr./Mrs./Miss. Pranav Kumar Peruru, of SRIT, Anantapur has participated and presented a paper entitled Micro Safe : IoT Based Smart Helmet for Mining Workers with Paper ID: ICIAET-P275 in ICIAET-2024.

Dr V Mahesh Kumar Reddy  
Convener & Organising Chair

Dr G Sreenivasula Reddy  
Principal, CBIT



Official sponsor



**CHAITANYA BHARATHI**  
**INSTITUTE OF TECHNOLOGY**  
(UGC-AUTONOMOUS)  
PRODDATUR

Vidya Nagar, Proddatur, YSR Kadapa (Dist.),  
Andhra Pradesh 516360



ICIAET-24  
Proceedings

*International Conference on Innovative Approaches in  
Engineering & Technology (ICIAET-24)*  
5<sup>th</sup> & 6<sup>th</sup> April 2024

Organized by Department of Electrical & Electronics Engineering

Certificate of Appreciation

This certificate is awarded to Dr./Mr./Mrs. Yashaswini Jawalkar, of  
SPTI, Anantapur has participated and presented a paper entitled  
Mine Safe: IoT Based Smart Helmet for Mining Workers  
with Paper ID: ICIAET-P275 in ICIAET-2024.

Dr V Mahesh Kumar Reddy  
Convener & Organising Chair

Dr G Sreenivasula Reddy  
Principal, CBIT



Official sponsor



**CHAITANYA BHARATHI**  
**INSTITUTE OF TECHNOLOGY**  
(UGC-AUTONOMOUS)

PRODDATUR  
Vidya Nagar, Proddatur, YSR Kadapa (Dist.),  
Andhra Pradesh 516360



ICIAET-24  
Proceedings

*International Conference on Innovative Approaches in  
Engineering & Technology (ICIAET-24)*  
5<sup>th</sup> & 6<sup>th</sup> April 2024

Organized by Department of Electrical & Electronics Engineering

Certificate of Appreciation

This certificate is awarded to Dr./Mr./Mrs./Miss. Pavan Reddy of SRTI, Anaparthi has participated and presented a paper entitled Mine Safe: IoT Based Smart Helmet for Mining Workers with Paper ID: ICIAET-P235 in ICIAET-2024.

Dr V Mahesh Kumar Reddy  
Convener & Organising Chair

Dr G Sreenivasula Reddy  
Principal, CBIT



Official sponsor



**CHAITANYA BHARATHI**  
**INSTITUTE OF TECHNOLOGY**  
(UGC-AUTONOMOUS)

PRODDATUR

Vidya Nagar, Proddatur, YSR Kadapa (Dist.),  
Andhra Pradesh 516360



ICIAET-24  
Proceedings

*International Conference on Innovative Approaches in  
Engineering & Technology (ICIAET-24)*  
5<sup>th</sup> & 6<sup>th</sup> April 2024

*Organized by Department of Electrical & Electronics Engineering*

Certificate of Appreciation

This certificate is awarded to Dr./Mr./Mrs./Miss. Tofel Basba Megal, of  
SRTI, Anantapur has participated and presented a paper entitled  
Mine Safe : IOT based Smart Helmet for Mining Workers  
\_\_\_\_\_ with Paper ID: ICIAET - P275 in ICIAET-2024.

Dr V Mahesh Kumar Reddy  
Convenor & Organising Chair

Dr G Sreenivasula Reddy  
Principal, CBIT

**turnitin**  
Official sponsor



**CHAITANYA BHARATHI**  
**INSTITUTE OF TECHNOLOGY**  
(UGC- AUTONOMOUS)  
PRODDATUR  
Vidya Nagar, Proddatur, YSR Kadapa (Dist.),  
Andhra Pradesh 516360



ICIAET-24  
Proceedings

*International Conference on Innovative Approaches in  
Engineering & Technology (ICIAET-24)  
5<sup>th</sup> & 6<sup>th</sup> April 2024*

*Organized by Department of Electrical & Electronics Engineering*

*Certificate of Appreciation*

This certificate is awarded to Dr./Mr./Mrs./Miss. Divya Pomgala of SRTI, Anantapur has participated and presented a paper entitled Mine Safe: IoT Based Smart Helmet for Mining Workers with Paper ID: ICIAET-P2-75 in ICIAET-2024.

Dr V Mahesh Kumar Reddy  
Convener & Organising Chair

Dr G Sreenivasula Reddy  
Principal, CBIT

**turnitin**  
Official sponsor